

CHAPTER 7435
DEPARTMENT OF PUBLIC SAFETY
STATE PATROL DIVISION
BRAKE TESTING STATIONS

7435.0200 BASIC PROVISIONS
 7435.0300 APPLICATION INSTRUCTIONS.
 7435.0400 BASIC REQUIREMENTS FOR BRAKE
 STATIONS.
 7435.0500 REVOCATION OF CERTIFICATES.
 7435.0600 CERTIFICATE OF BRAKE
 ADJUSTMENT.

7435.0700 RECORDS
 7435.0800 SERVICE INFORMATION.
TABLES, FORMS, AND EXHIBITS
 7435.9910 DIAGRAM OF TYPICAL PASSENGER
 CAR BRAKE ADJUSTING STATION.

7435.0200 BASIC PROVISIONS.

Official brake adjusting and testing stations are established and appointed for the purpose of increasing safety on the highway. It is important that every official station properly instruct all employees in the helpful attitude that should be maintained toward the public and in the proper procedure of brake service work and adjustments. Continued supervision of all mechanics who are authorized to make inspections, repairs, and adjustments must be maintained to assure the public of uniformly high standards of workmanship.

Statutory Authority: *MS s 169.77*

7435.0300 APPLICATION INSTRUCTIONS.

Subpart 1. **Application form.** Application for designation as official brake adjusting and testing station must be made upon a form which may be procured from the Minnesota Department of Public Safety, State Patrol Division, Transportation Building, Saint Paul, Minnesota 55155.

Subp. 2. **Inspection upon application.** Upon receipt of completed application an inspection will be made. Approval or rejection will follow such inspection subject to parts 7435.0300 to 7435.0800 and 7435.9910.

Each application shall bear the statement that the proposed station is suitable.

Subp. 3. **Classification.** Stations will be classified as A or B passenger car and as A or B truck and bus stations, as hereinafter defined.

A. "Passenger car stations" are those with equipment, space, and service facilities to properly test, repair, and adjust brakes on passenger cars and light trucks up to and including one ton but not to include any vehicle with power brake equipment.

B. "Truck and bus stations" are those with the equipment, space, and service facilities to properly test, repair, and adjust brakes on trucks, buses, trailers, tractors, and truck tractors.

C. "Class A stations" are those equipped with a brake tester or other testing devices approved by the commissioner of public safety for use in official brake adjusting and testing stations. Approved testing devices shall be capable of indicating the stopping distance of the vehicle, the braking effort of each wheel, and the percentage of equalization.

D. "Class B stations" are those without brake testers but with adequate floor space or driveway space either inside or outside the building for making trial stops of the vehicle.

Subp. 4. **Revocation.** Any certificates of designation of official brake adjusting and testing station issued may be subsequently revoked for cause.

Statutory Authority: *MS s 169.77*

MINNESOTA RULES 1985

7435.0400 BRAKE TESTING STATIONS

6426

7435.0400 BASIC REQUIREMENTS FOR BRAKE STATIONS.

Subpart 1. **Sign.** Official stations must have a sign secured from the commissioner of public safety, displayed in front of the place of business. These signs are furnished at cost by the commissioner of public safety.

Subp. 2. **Mechanic on duty; qualifications.** Each official brake adjusting and testing station must have at least one automotive mechanic approved by the commissioner of public safety who is capable of adjusting brakes. Such approval shall be evidenced by a certificate naming such individual. In order to obtain such certificate he must meet the following qualifications for brake adjusters:

A. The applicant for brake adjuster shall be of good character, over 21 years of age, with at least four years experience in general automotive repair work or two years specialized brake work. Evidence of experience shall be shown on the application form provided including certification by shop foreman, garage owner, or such other officials as indicated on the application form as acceptable.

B. Each applicant must pass such examination both written and practical or manual as may be prescribed from time to time by the commissioner of public safety. In the event any applicant shall fail to pass any such examination, he may (but is not required to) take a course of training concerning the testing and adjusting of brakes on vehicles given by the Dunwoody Industrial Institute, 818 Wayzata Boulevard, Minneapolis, Minnesota. If upon completion of said course and if said Dunwoody Institute shall report that the applicant has submitted proper application, has met the training requirements, and has passed with a satisfactory mark and has satisfactorily passed an examination given by the Dunwoody Institute and an examination prescribed by the commissioner of public safety at the conclusion of his course of training, a certificate of appointment as brake adjuster will be issued for one year. Training information may be obtained from the Department of Public Safety or Dunwoody Institute. Any applicant who fails to pass an examination is not precluded from taking further examination from time to time as they may be given.

C. The length of training courses given by Dunwoody Institute for certified adjusters will not exceed: passenger car, five days of eight hours each maximum or night classes of equivalent hours; truck and bus, five days of eight hours each maximum or night classes of equivalent hours.

D. Official brake adjusters will be certified as passenger car or as truck and bus adjusters. Adjusters may have both a passenger car and a truck and bus classification.

E. Renewals of the certificate of appointment as official brake adjuster may be granted upon application. Brake adjusters' appointments are subject to cancellation.

Subp. 3. **Certificate posted.** The certificate of designation of official brake adjusting and testing station and certificate of authority of brake adjusters must be posted in a conspicuous place within the testing space.

Subp. 4. **Certified work.** Official brake adjusting and testing must be performed by the certified adjuster only or under his direct supervision. He is directly responsible for the quality of workmanship in both brake repairs and adjustments.

The designated adjuster is the only person who may sign and issue the certificate of brake adjustment to drivers of vehicles whose brakes have been tested or adjusted.

Subp. 5. **Tools.** Official adjusting and testing stations must be equipped with suitable tools, sufficient for making the necessary tests, adjustments, and repairs.

MINNESOTA RULES 1985

6427

BRAKE TESTING STATIONS 7435.0600

Subp. 6. **Space for brake testing.** Space is required for testing brakes as follows:

A. Class A station must have at least three feet in the clear to each side of brake tester, a clear run on space in front of testers of not less than 20 feet for passenger car stations and 30 feet for truck stations, and the testing space shall be of sufficient area to allow for installation of equipment with the clearances provided for in this item. See diagram in part 7435.9910.

B. Class B station must have a testing space at least 12 feet wide and of sufficient length to bring vehicle up to speed of 20 mph and to safely stop the vehicle. If a decelerometer or other approved test device is used, less length will be needed, as test can be made at ten mph or in some cases with vehicle at rest. Class B stations must also have at least one stall or work space sufficient to handle vehicles of legal size for which the station is approved. Testing space and service stall must be kept orderly and clean and clearly defined.

Subp. 7. **Installation.** Test equipment must be installed in a manner satisfactory to the commissioner of public safety.

Subp. 8. **Brake adjusting fees.** Charges for adjusting and repair work shall not exceed regular hourly rates or flat rates whichever is used by the shop.

Subp. 9. **Inspections.** Official brake adjusting and testing stations will be inspected from time to time by state patrol officers or other duly authorized agents of the commissioner of public safety.

Statutory Authority: *MS s 169.77*

7435.0500 REVOCATION OF CERTIFICATES.

The certificate designating official brake adjusting and testing stations and the certificate of authority of brake adjuster may be revoked for cause without notice by the commissioner of public safety and such revocation will cancel authority for any place of business to function as an official brake adjusting and testing station and for any adjuster to make adjustments as an official adjuster or to sign certificates of adjustment. When the designation of official brake adjusting and testing station has been revoked, he shall surrender such certificate and any unused adjustment certificate forms to any duly authorized agent of the commissioner of public safety. When an adjuster's certificate has been revoked, he shall surrender such certificate to any duly authorized agent of the commissioner of public safety. If such revocation was because of failure in an examination or lack of knowledge as to procedure in brake repair and adjustment or because the adjuster allowed his certificate to lapse, the adjuster may apply for reinstatement, which reinstatement may be made providing the adjuster meets the qualifications of brake adjuster.

A station may be canceled for poor workmanship, unreasonable charges, or for any violation of parts 7435.0200 to 7435.0800 and 7435.9910.

Statutory Authority: *MS s 169.77*

7435.0600 CERTIFICATE OF BRAKE ADJUSTMENT.

After satisfactorily repairing, adjusting, or testing the brakes on any vehicle, official stations are authorized to issue to the driver of the vehicle a certificate of brake adjustment. The commissioner of public safety will furnish at cost official forms of certificate of brake adjustment to each official station upon request. These certificates of brake adjustment as completed must contain the following: date of issue, registration number of the motor vehicle, owner's name, make of vehicle, and official designation of the adjusting station. The forms of certificates furnished by the commissioner of public safety will be in triplicate. They shall be signed by the certified official brake adjuster, and after execution the original thereof shall be delivered to the driver, a copy retained by the station, and a copy transmitted to the law enforcement agency that has given the driver a written notice to have his brakes adjusted or repaired.

MINNESOTA RULES 1985

7435.0600 BRAKE TESTING STATIONS

6428

Each official station shall keep an adequate supply of certificates on hand. Certificates shall be issued in numerical order.

Statutory Authority: *MS s 169.77*

7435.0700 RECORDS.

Each official station shall keep both used and unused books of certificates in numerical order, in a file or cabinet convenient to the brake adjusting space. Used books shall be segregated from unused books.

The stations's copy of the certificate shall remain in the book.

The station shall retain copies of certificates of brake adjustment until such time as the duly authorized agent of the commissioner of public safety has inspected the station and checked the certificates and has authorized the disposal thereof.

Statutory Authority: *MS s 169.77*

7435.0800 SERVICE INFORMATION.

Whenever necessary, the commissioner of public safety will issue bulletins and instructions dealing with brake operation, tolerances, service, and inspection procedure.

Statutory Authority: *MS s 169.77*

TABLES, FORMS, AND EXHIBITS

7435.9910 DIAGRAM OF TYPICAL PASSENGER CAR BRAKE ADJUSTING STATION.

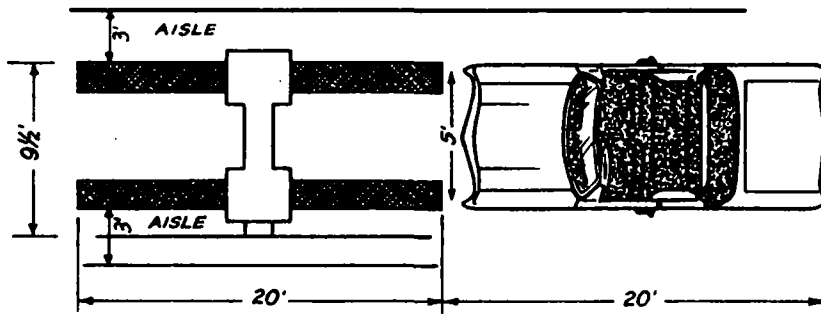

Typical Passenger Car Station

Statutory Authority: *MS s 169.77*