

**CHAPTER 7080**  
**MINNESOTA POLLUTION CONTROL AGENCY**  
**WATER QUALITY DIVISION**  
**INDIVIDUAL SEWAGE TREATMENT SYSTEMS**

7080.0010	PURPOSE AND INTENT.	7080.0110	SITE EVALUATION.
7080.0020	DEFINITIONS.	7080.0120	BUILDING SEWERS.
7080.0030	ADMINISTRATION BY STATE AGENCIES.	7080.0130	SEWAGE TANKS.
7080.0040	ADMINISTRATION BY MUNICIPALITIES.	7080.0150	DISTRIBUTION OF EFFLUENT.
7080.0050	SURFACE DISCHARGE.	7080.0160	DOSING OF EFFLUENT.
7080.0060	TREATMENT REQUIRED.	7080.0170	FINAL TREATMENT AND DISPOSAL.
7080.0070	SYSTEM COMPONENTS.	7080.0180	ALTERNATIVE SYSTEMS.
7080.0080	PROHIBITED INSTALLATIONS.	7080.0190	SEVERABILITY.
7080.0090	SYSTEM SIZING.	7080.0200	VARIANCE.
7080.0100	ADVISORY COMMITTEE.	7080.0210	APPENDIX A: ALTERNATIVE SYSTEMS.

**7080.0010 PURPOSE AND INTENT.**

The improper design, location, installation, use, and maintenance of individual sewage treatment systems adversely affects the public health, safety, and general welfare by discharge of inadequately treated sewage to surface and ground waters. In accordance with the authority granted in Minnesota Statutes, chapters 104, 105, 115, and 116, the Minnesota Pollution Control Agency, hereinafter referred to as the agency, does hereby provide the minimum standards and criteria for the design, location, installation, use, and maintenance of individual sewage treatment systems, and thus protect the surface and ground waters of the state, and promote the public health and general welfare. These standards are most effective when applied in conjunction with local planning and zoning that considers the density of the systems that are discharging to the groundwater. These standards are not intended to cover systems treating industrial waste or other wastewater that may contain hazardous materials.

Further, it is intended that the administration and enforcement of these standards be conducted by municipalities, since experience has shown that sanitary ordinances can most effectively be administered at the local level.

**Statutory Authority:** *MS s 115.03 subd 1*

**History:** *13 SR 2752*

**7080.0020 DEFINITIONS.**

Subpart 1. **Certain terms.** For the purposes of these standards, certain terms or words used herein shall be interpreted as follows: the words "shall" and "must" are mandatory, the words "should" and "may" are permissive. All distances, unless otherwise specified, shall be measured horizontally.

Subp. 1a. **Absorption area.** "Absorption area" means the area below a mound that is designed to absorb effluent.

Subp. 1b. **Additive, individual sewage treatment system.** "Additive, individual sewage treatment system" means a product which is added to the wastewater or to the system to improve the performance of an individual sewage treatment system.

Subp. 2. **Aerobic tank.** "Aerobic tank" means any sewage tank which utilizes the principle of oxidation in the decomposition of sewage by the introduction of air into the sewage.

Subp. 3. **Agency.** "Agency" means the Minnesota Pollution Control Agency.

Subp. 4. **Alternative system.** "Alternative system" means an individual sewage treatment system employing such methods and devices as presented in part 7080.0180.

Subp. 5. **Baffle.** "Baffle" means a device installed in a septic tank for proper operation of the tank and to provide maximum retention of solids, and includes vented sanitary tees and submerged pipes in addition to those devices that are normally called baffles.

Subp. 6. **Bedrock.** "Bedrock" means that layer of parent material which is consolidated and unweathered.

Subp. 7. **Bedroom.** "Bedroom" means any room within a dwelling that might reasonably be used as a sleeping room.

Subp. 8. **Building drain.** "Building drain" means that part of the lowest piping of the drainage system which receives the sewage discharge inside the walls of the building and conveys it to the building sewer beginning at least one foot outside the building footings.

Subp. 9. **Building sewer.** "Building sewer" means that part of the drainage system which extends from the end of the building drain and conveys its discharge to an individual sewage treatment system.

Subp. 10. **Capacity.** "Capacity" means the liquid volume of a sewage tank using inside dimensions below the outlet.

Subp. 11. **Cesspool.** "Cesspool" means an underground pit into which raw household sewage or other untreated liquid waste is discharged and from which the liquid seeps into the surrounding soil. See part 7080.0080.

Subp. 12. **DNR.** "DNR" means the Minnesota Department of Natural Resources.

Subp. 13. **Distribution pipes.** "Distribution pipes" means perforated pipes that are used to distribute sewage tank effluent in a soil treatment system.

Subp. 14. **Dosing chamber, or pump pit, or wet well.** "Dosing chamber, or pump pit, or wet well" means a tank or separate compartment following the sewage tank which serves as a reservoir for the dosing device.

Subp. 15. **Dosing device.** "Dosing device" means a pump, siphon, or other device that discharges sewage tank effluent from the dosing chamber to the soil treatment system.

Subp. 15a. **Drainfield rock.** "Drainfield rock" means crushed igneous rock, or similar insoluble, durable, and decay-resistant material with no more than five percent by weight passing a number 4 sieve and no more than one percent by weight passing a number 200 sieve. The size shall range from three-fourths inch to 2-1/2 inches.

Subp. 16. **Dwelling.** "Dwelling" means any building or place used or intended to be used by human occupants as a single family or two family unit.

Subp. 17. [Repealed, 13 SR 2752]

Subp. 18. **Greywater.** "Greywater" means liquid waste from a dwelling or other establishment produced by bathing, laundry, culinary operations, and from floor drains associated with these sources, and specifically excluding toilet waste.

Subp. 18a. **Hazardous materials.** "Hazardous materials" means any substance which, when discarded, meets the definition of hazardous waste in chapter 7045.

Subp. 19. **Holding tank.** "Holding tank" means a watertight tank for storage of sewage until it can be transported to a point of approved treatment and disposal.

Subp. 20. **Impermeable.** "Impermeable," with regard to bedrock, means a bedrock having no cracks or crevices and having a vertical permeability slower than one inch in 24 hours shall be considered impermeable. With regard to soils, a soil horizon or layer having a vertical permeability slower than 0.025 inch in 24 hours shall be considered impermeable.

Subp. 21. **Individual sewage treatment system.** "Individual sewage treatment system" means a sewage treatment system, or part thereof, serving a dwelling, or other establishment, or group thereof, which uses subsurface soil treatment and disposal.

Subp. 21a. **Invert.** "Invert" means the lowest point of a channel inside a pipe.

Subp. 22. [Repealed, 13 SR 2752]

Subp. 22a. **Maximum monthly average daily flow.** "Maximum monthly average daily flow" means the 30-day average daily flow for the highest consecutive 30-day period during the year.

Subp. 23. **Mottling.** "Mottling" means a zone of chemical oxidation and reduction activity, appearing as splotchy patches of red, brown, orange, and gray in the soil.

Subp. 24. **Mound system.** "Mound system" means a system where the soil treatment area is built above the ground to overcome limits imposed by proximity to water table or bedrock, or by rapidly or slowly permeable soils.

Subp. 24a. **Municipality.** "Municipality" means any county, city, town, the Metropolitan Waste Control Commission established in chapter 473, the Metropolitan Council when acting under the provisions of that chapter, or any other governmental subdivision of the state responsible by law for the prevention, control, and abatement of water pollution in any area of the state.

# MINNESOTA RULES 1993

1055

## INDIVIDUAL SEWAGE TREATMENT SYSTEMS 7080.0020

Subp. 24b. **Ordinary high water level.** "Ordinary high water level" means the boundary of public waters and wetlands, that is an elevation delineating the highest water level maintained for a sufficient period of time to leave evidence upon the landscape, commonly that point where the natural vegetation changes from predominantly aquatic to predominantly terrestrial. For watercourses, the ordinary high water level is the elevation of the top of the bank of a channel. For reservoirs and flowages the ordinary high water level must be the operating elevation of the normal summer pool.

Subp. 24c. **Original soil.** "Original soil" means naturally occurring inorganic soil that has not been moved, smeared, compacted, nor manipulated with construction equipment.

Subp. 25. **Other establishment.** "Other establishment" means any public or private structure other than a dwelling which generates sewage.

Subp. 25a. **Owner.** "Owner" means all persons having possession of, control over, or title to an individual sewage treatment system.

Subp. 26. **Percolation rate.** "Percolation rate" means the time rate of drop of a water surface in a test hole as specified in part 7080.0110, subpart 4.

Subp. 27. **Permitting authority.** "Permitting authority" means any state agency or municipality which administers the provisions of these standards.

Subp. 28. **Plastic limit.** "Plastic limit" means a soil moisture content below which the soil may be manipulated for purposes of installing a soil treatment system, and above which manipulation will cause compaction and puddling. The soil moisture content at the plastic limit can be measured by American Society for Testing and Materials (ASTM) test number D4318-84.

Subp. 28a. **Public waters.** "Public waters" means any public waters or wetlands as defined in Minnesota Statutes, section 105.37, subdivisions 14 and 15 or identified as public waters or wetlands by the inventory prepared pursuant to Minnesota Statutes, section 105.391.

Subp. 28b. **Required absorption width.** "Required absorption width" means that width, measured in the direction of the original land slope and perpendicular to the original contours, which is required for the sewage tank effluent to infiltrate into the original soil according to the allowable loading rates of Table V in part 7080.0170, subpart 2, item G.

Subp. 28c. **Restaurants.** "Restaurants" means establishments that prepare and serve meals and at which multiple use dishes and utensils are washed.

Subp. 29. **Sand.** "Sand" means a soil texture composed by weight of at least 25 percent very coarse, coarse, and medium sand varying in size from 2.00 millimeters (sieve size 10) to 0.25 millimeters (sieve size 60), less than 40 percent fine or very fine sand ranging in size between 0.25 millimeters and 0.05 millimeters (sieve size 270), and no more than ten percent particles smaller than 0.05 millimeters.

Subp. 30. **Seepage pit, or leaching pit, or dry well.** "Seepage pit, or leaching pit, or dry well" means an underground pit into which a sewage tank discharges effluent or other liquid waste and from which the liquid seeps into the surrounding soil through the bottom and openings in the side of the pit.

Subp. 31. **Septage.** "Septage" means those solids and liquids removed during periodic maintenance of a septic or aerobic tank, or those solids and liquids which are removed from a holding tank.

Subp. 32. **Setback.** "Setback" means a separation distance measured horizontally.

Subp. 33. **Sewage.** "Sewage" means any water carried domestic waste, exclusive of footing and roof drainage, from any industrial, agricultural, or commercial establishment, or any dwelling or any other structure. Domestic waste includes liquid waste produced by toilets, bathing, laundry, culinary operations, and the floor drains associated with these sources, and specifically excludes animal waste and commercial or industrial waste water.

Subp. 34. **Sewage flow.** "Sewage flow" means flow as determined by measurement of actual water use or, if actual measurements are unavailable, as estimated by the best available data provided by the agency.

Subp. 35. **Sewage tank.** "Sewage tank" means a watertight tank used in the treatment of sewage and includes, but is not limited to, septic tanks and aerobic tanks.

Subp. 36. **Sewage tank effluent.** "Sewage tank effluent" means that liquid which flows from a septic or aerobic tank under normal operation.

Subp. 37. **Septic tank.** "Septic tank" means any watertight, covered receptacle designed and constructed to receive the discharge of sewage from a building sewer, separate solids from liquid, digest organic matter, and store liquids through a period of detention, and allow the clarified liquids to discharge to a soil treatment system.

Subp. 38. **Shoreland.** "Shoreland" means land located within the following distances from public waters: 1,000 feet from the ordinary high water mark of a lake, pond or flowage; and 300 feet from a river or stream or the landward extent of a flood plain designated by ordinance on such a river or stream, whichever is greater.

Subp. 39. **Site.** "Site" means the area bounded by the dimensions required for the proper location of the soil treatment system.

Subp. 40. **Slope.** "Slope" means the ratio of vertical rise or fall to horizontal distance.

Subp. 41. **Soil characteristics, limiting.** "Soil characteristics, limiting" means those soil characteristics which preclude the installation of a standard system, including evidence of water table or bedrock and percolation rates faster than one-tenth or slower than 120 minutes per inch.

Subp. 42. **Soil textural classification.** "Soil textural classification," where soil particle sizes or textures are specified in this chapter, they refer to the soil textural classification in the Soil Survey Manual, Handbook No. 18, United States Department of Agriculture, 1951.

Subp. 43. **Soil treatment area.** "Soil treatment area" means that area of trench or bed bottom which is in direct contact with the drainfield rock of the soil treatment system, and for mounds, that area to the edges of the required absorption width and extending five feet beyond the ends of the rock layer.

Subp. 44. **Soil treatment system.** "Soil treatment system" means a system where sewage tank effluent is treated and disposed of below the ground surface by filtration and percolation through the soil, and includes those systems commonly known as seepage bed, trench, drainfield, disposal field, and mounds.

Subp. 45. **Standard system.** "Standard system" means an individual sewage treatment system employing a building sewer, sewage tank, and the soil treatment system consisting of trenches, seepage beds, or mounds which are constructed on original soil which has a percolation rate equal to or faster than 120 minutes per inch.

Subp. 46. **Surface water flooding.** "Surface water flooding" means the 100-year flood plain along rivers and streams as defined by the Department of Natural Resources, or in the absence of such data, as defined by the largest flood of record; on lakes, high water levels as determined or recorded by the Department of Natural Resources or, in the case of no Department of Natural Resources record, by local records or experience. Other surface water flooding or high water areas should be determined by local information.

Subp. 47. **Ten-year flood.** "Ten-year flood" means that flood which can be expected to occur, on an average, of once in ten years; or the level to which flood waters have a ten percent chance of rising in any given year.

Subp. 48. **Toilet waste.** "Toilet waste" means fecal matter, urine, toilet paper, and any water used for flushing.

Subp. 49. **Valve box.** "Valve box" means any device which stops sewage tank effluent from flowing to a portion of the soil treatment area, and includes, but is not limited to, caps or plugs on distribution or drop box outlets, divider boards, butterfly valves, gate valves, or other mechanisms.

Subp. 50. **Water table.** "Water table" means the highest elevation in the soil where all voids are filled with water, as evidenced by presence of water or soil mottling or other information.

Subp. 51. [Repealed, 13 SR 2752]

Subp. 52. **Watertight.** "Watertight" means a sewage tank constructed so that no water can get into or out of the sewage tank except through the inlet and outlet pipes.

Subp. 53. **Wild and scenic river land use district.** "Wild and scenic river land use district" means those lands designated by the commissioner of the Department of Natural Resources.

# MINNESOTA RULES 1993

1057

## INDIVIDUAL SEWAGE TREATMENT SYSTEMS 7080.0050

sources as the protected land corridor along those rivers or river segments designated as wild, scenic, or recreational rivers.

**Statutory Authority:** *MS s 115.03 subd 1*

**History:** *13 SR 2752*

### 7080.0030 ADMINISTRATION BY STATE AGENCIES.

For an individual sewage treatment system, or group of individual sewage treatment systems, that are located on adjacent properties and under single ownership, the owner or owners shall make application for and obtain a state disposal system permit from the agency if either of the following conditions apply:

A. the individual sewage treatment system or systems are designed to treat an average daily flow greater than 10,000 gallons per day; or

B. the individual sewage treatment system or systems are designed to treat a maximum monthly average daily flow of 15,000 gallons per day or more.

The systems must, at a minimum, conform to the requirements of these standards.

For dwellings such as rental apartments, townhouses, resort units, rental cabins, and condominiums, the sum of the flows from all existing and proposed sources under single management or ownership will be used to determine the need for a state disposal system permit.

Individual sewage treatment systems serving establishments or facilities licensed or otherwise regulated by the state of Minnesota shall conform to the requirements of these standards.

Any individual sewage treatment system requiring approval by the state of Minnesota shall also comply with all local codes and ordinances.

**Statutory Authority:** *MS s 115.03 subd 1*

**History:** *13 SR 2752*

### 7080.0040 ADMINISTRATION BY MUNICIPALITIES.

Subpart 1. **Shoreland and floodplain areas, and wild scenic river land use districts.** Pursuant to Minnesota Statutes, sections 104.04, 104.36, and 105.485, certain counties and cities must enact ordinances which comply with the appropriate regulations of the Minnesota Department of Natural Resources, some of which in turn require compliance with the regulations of the Minnesota Pollution Control Agency.

Subp. 2. **Other areas.** Outside of the above mentioned areas, these standards provide recommended guidelines for the adoption of local ordinances and for the design, location, construction, use, and maintenance of individual sewage treatment systems.

Subp. 3. **Localized standards.** Nothing in these standards shall prevent municipalities from enacting ordinances which provide more adequate sewage treatment under local conditions.

Subp. 4. **Inspection and approval.** If a municipality issues construction permits under these standards for individual sewage treatment systems, the municipality or its authorized representative must inspect and approve systems according to these standards. The municipality must maintain records of the location and design of the systems.

**Statutory Authority:** *MS s 115.03 subd 1*

**History:** *13 SR 2752*

### 7080.0050 SURFACE DISCHARGE.

Unless specifically permitted by the agency, sewage, sewage tank effluent, or seepage from a soil treatment system shall not be discharged to the ground surface, abandoned wells, or bodies of surface water, or into any rock or soil formation the structure of which is not conducive to purification of water by filtration, or into any well or other excavation in the ground.

All new or existing systems which discharge to surface waters or the ground surface must obtain either a National Pollutant Discharge Elimination System (NPDES) or State Disposal System Permit from the agency and shall comply with all requirements pertaining thereto.

**Statutory Authority:** *MS s 115.03 subd 1*

**7080.0060 TREATMENT REQUIRED.**

The system, or systems, shall be designed to receive all sewage from the dwelling, building, or other establishment served. Footing or roof drainage shall not enter any part of the system. Products containing hazardous materials must not be discharged to the system other than a normal amount of household products and cleaners designed for household use. Substances not used for household cleaning, including solvents, pesticides, flammables, photo finishing chemicals, or dry cleaning chemicals, must not be discharged to the system.

Systems that were installed according to all applicable local standards adopted and in effect at the time of installation shall be considered as conforming unless they are determined to be failing, except that systems using cesspools, leaching pits, or seepage pits, or systems with less than three feet of unsaturated soil or sand between the distribution device and the limiting soil characteristics shall be considered nonconforming.

**Statutory Authority:** *MS s 115.03 subd 1*

**History:** *13 SR 2752*

**7080.0070 SYSTEM COMPONENTS.**

The system shall consist of a building sewer, sewage tank, and soil treatment system. All sewage shall be treated in a sewage tank or toilet waste treatment device, and the sewage tank effluent shall be discharged to the soil treatment system.

**Statutory Authority:** *MS s 115.03 subd 1*

**7080.0080 PROHIBITED INSTALLATIONS.**

Cesspools, seepage pits, dry wells, and leaching pits shall not be installed.

**Statutory Authority:** *MS s 115.03 subd 1*

**History:** *13 SR 2752*

**7080.0090 SYSTEM SIZING.**

Where the construction of additional bedrooms, the installation of mechanical equipment, or other factors likely to affect the operation of the system can be reasonably anticipated, the installation of a system for such anticipated need shall be required.

**Statutory Authority:** *MS s 115.03 subd 1*

**7080.0100 ADVISORY COMMITTEE.**

Subpart 1. **Creation.** There is created an advisory committee on individual sewage treatment systems (ISTS) hereinafter referred to as the committee.

Subp. 2. **Duties.** The committee shall, subject to the approval of the agency, review and advise the agency on:

- A. revisions of standards and legislation relating to ISTS;
- B. technical data relating to ISTS;
- C. a technical manual on ISTS;
- D. educational materials and programs for ISTS;
- E. the administration of standards and ordinances pertaining to ISTS at the state and local levels; and
- F. other ISTS activities considered appropriate by the committee.

Subp. 3. **Membership.** The committee shall consist of 16 voting members. Of the 16 voting members:

- A. one shall be a citizen of Minnesota, representative of the public;
- B. one shall be from the Minnesota Extension Service of the University of Minnesota;
- C. six shall be county administrators (such as zoning administrators, sanitarians, etc.), one from each of the five agency regions and one from the seven-county metropolitan area;
- D. one shall be a municipal building inspector;
- E. six shall be sewage treatment contractors, one from each of the five agency regions and one from the seven-county metropolitan area; and

# MINNESOTA RULES 1993

1059

## INDIVIDUAL SEWAGE TREATMENT SYSTEMS 7080.0110

F. one shall be a water well contractor.

**Subp. 4. Ex officio members.** The following agencies and associations shall each have one nonvoting ex officio member to assist the advisory committee and to be advised, in turn, on matters relating to ISTS: the agency, the DNR, Department of Health, the United States Department of Agriculture Soil Conservation Service, the Metropolitan Council, the Association of Minnesota Counties, the Minnesota Association of Townships, the League of Minnesota Cities, and the Minnesota Society of Professional Engineers.

**Subp. 5. Appointment; terms.** All members shall be appointed by the agency board from recommendations by the affected groups. All members shall serve for four years, with terms staggered so as to maintain continuity.

In the case of a vacancy, an appointment shall be made for the unexpired balance of the term. The administrators, inspectors, and contractors shall have been bona fide residents of this state for a period of at least three years before appointment, and shall have had at least three years' experience in their respective businesses.

**Subp. 6. Robert's rules.** Robert's Rules of Order shall prevail at all meetings of the advisory committee.

**Statutory Authority:** *MS s 115.03 subd 1*

**History:** *13 SR 2752*

### 7080.0110 SITE EVALUATION.

**Subpart 1. Evaluation factors.** All proposed sites for individual sewage treatment systems shall be evaluated as to:

- A. depth to the highest known or calculated ground water table or bedrock;
- B. soil conditions, properties, and permeability;
- C. slope;
- D. the existence of lowlands, local surface depressions, and rock outcrops;
- E. all legal setback requirements from: existing and proposed buildings; property lines; sewage tanks; soil treatment systems; water supply wells; buried water pipes and utility lines; the ordinary high water level of public waters; and the location of all soil treatment systems and water supply wells on adjoining lots within 150 feet of the proposed soil treatment system, sewage tank, and water supply well; and
- F. surface water flooding probability.

**Subp. 2. Preliminary evaluation.** A preliminary evaluation shall be made of publicly available, existing data. If this evaluation, in the opinion of the permitting authority, yields enough information that the site is suitable, approval may be given for the installation of a standard system as specified in part 7080.0170, subpart 2. If a preliminary evaluation does not produce sufficient information, a field evaluation shall be made to determine the necessary information as specified in subpart 1.

**Subp. 3. Procedures for soil borings.** Where soil borings are required, they shall be made as follows:

A. Each boring or excavation shall be made to a depth at least three feet deeper than the bottom of the proposed system or until bedrock or a water table is encountered, whichever is less.

B. A soil texture description shall be recorded by depth and notations made where texture changes occur.

C. Particular effort shall be made to determine the highest known water table by recording the first occurrence of mottling observed in the hole, or if mottling is not encountered, the open holes in clay or loam soils shall be observed after standing undisturbed a minimum of 16 hours, and depth to standing water, if present, shall be measured.

**Subp. 4. Procedures for percolation tests.** Where percolation tests are required, they shall be made as follows:

A. Test hole dimensions and locations:

(1) Each test hole shall be six to eight inches in diameter, have vertical sides, and be bored or dug to the depth of the bottom of the proposed individual sewage treatment system.

(2) Soil texture descriptions shall be recorded noting depths where texture changes occur.

**B. Preparation of the test hole:**

(1) The bottom and sides of the hole shall be carefully scratched to remove any smearing and to provide a natural soil surface into which water may penetrate.

(2) All loose material shall be removed from the bottom of the test hole and two inches of one-fourth to three-fourths inch gravel shall be added to protect the bottom from scouring.

**C. Soil saturation and swelling:**

(1) The hole shall be carefully filled with clear water to a minimum depth of 12 inches over the soil at the bottom of the test hole and maintained for no less than four hours.

(2) The soil shall then be allowed to swell for at least 16, but no more than 30 hours. In sandy soils, the saturation and swelling procedure shall not be required and the test may proceed if one filling of the hole has seeped away in less than ten minutes.

**D. Percolation rate measurement:** In sandy soils adjust the water depth to eight inches over the soil at the bottom of the test hole. From a fixed reference point, the drop in water level shall be measured in inches to the nearest one-eighth inch at approximately ten minute intervals. A measurement can also be made by determining the time it takes for the water level to drop one inch from an eight-inch reference point. If eight inches of water seeps away in less than ten minutes, a shorter interval between measurements shall be used, but in no case shall the water depth exceed eight inches. The test shall continue until three consecutive percolation rate measurements vary by a range of no more than ten percent.

In other soils, adjust the water depth to eight inches over the soil at the bottom of the test hole. From a fixed reference point, the drop in water level shall be measured in inches to the nearest one-eighth inch at approximately 30-minute intervals, refilling between measurements to maintain an eight-inch starting head. The test shall continue until three consecutive percolation rate measurements vary by a range of no more than ten percent. The percolation rate can also be made by observing the time it takes the water level to drop one inch from an eight-inch reference point if a constant water depth of at least eight inches has been maintained for at least four hours prior to the measurement.

**E. Calculating the percolation rate.** Divide the time interval by the drop in water level to obtain the percolation rate in minutes per inch. Percolation rates determined for each test hole shall be averaged to determine the final soil treatment system design.

**F. Reporting percolation rates.** For reporting the percolation rate, worksheets showing all calculations and measurements shall be submitted.

**G. Frost.** A percolation test shall not be run where frost exists below the depth of the proposed soil treatment system.

**Subp. 5. Additional site.** If a suitable additional site is available, it must be identified in the site evaluation.

**Statutory Authority:** *MS s 115.03 subd 1*

**History:** *13 SR 2752*

### 7080.0120 BUILDING SEWERS.

**Subpart 1. Plumbing and Well Codes.** The design, construction, and location of, and the materials for use in building sewers are governed by the Minnesota State Building Code, chapter 1300, which incorporates by reference portions of the Minnesota Plumbing Code, chapter 4715, and by specific provisions of the Minnesota Water Well Construction Code, chapter 4725.

**Subp. 2. Water meter.** A new individual sewage treatment system that is intended to serve a new other establishment, as defined in part 7080.0020, subpart 25, must not be installed unless a water meter is provided to measure the flow to the treatment system. For metered systems that have septic tank effluent pumped to a soil treatment area, an electrical event counter must also be installed.

**Statutory Authority:** *MS s 115.03 subd 1*

**History:** *13 SR 2752*



# MINNESOTA RULES 1993

1061

## INDIVIDUAL SEWAGE TREATMENT SYSTEMS 7080.0130

### 7080.0130 SEWAGE TANKS.

Subpart 1. **In general.** All tanks, regardless of material or method of construction, must:

- A. be watertight;
- B. be designed and constructed to withstand all lateral earth pressures under saturated soil conditions with the tank empty;
- C. be designed and constructed with adequate tensile and compressive strength to withstand a minimum of seven feet of saturated earth cover above the tank top and manhole cover;
- D. not be subject to corrosion or decay; and
- E. have the manufacturer's name, model number, and tank capacity in gallons permanently displayed on the tank above the outlet pipe.

Any tank not having an integrally cast bottom shall not be installed when the water table is closer than three inches to the bottom of the excavation at the time of construction.

Subp. 2. **Design of septic tanks.** All tanks, regardless of material or method of construction, shall conform to the following criteria:

A. The liquid depth of any septic tank or compartment thereof shall be not less than 30 inches. A liquid depth greater than six and one-half feet shall not be considered in determining tank capacity.

B. No tank or compartment thereof shall have an inside horizontal dimension less than 24 inches.

C. Inlet and outlet connections of the tank shall be submerged by means of baffles.

D. The space in the tank between the liquid surface and the top of the inlet and outlet baffles shall be not less than 20 percent of the total required liquid capacity, except that in horizontal cylindrical tanks this space shall be not less than 15 percent of the total required liquid capacity.

E. Inlet and outlet baffles shall be constructed of acid resistant concrete, acid resistant fiberglass, or plastic.

F. Baffles must be integrally cast with the tank, affixed with a permanent waterproof adhesive, or affixed with stainless steel connectors, top and bottom. Sanitary tees, which are used as baffles, shall be affixed to the inlet or outlet pipes with a permanent waterproof adhesive.

G. The inlet baffle shall extend at least six inches but not more than 20 percent of the total liquid depth below the liquid surface and at least one inch above the crown of the inlet sewer.

H. The outlet baffle and the baffles between compartments shall extend below the liquid surface a distance equal to 40 percent of the liquid depth except that the penetration of the indicated baffles or sanitary tees for horizontal cylindrical tanks shall be 35 percent of the total liquid depth. They also shall extend above the liquid surface as required in item D. In no case shall they extend less than six inches above the liquid surface.

I. There shall be at least one inch between the underside of the top of the tank and the highest point of the inlet and outlet devices.

J. The inlet invert shall be not less than three inches above the outlet invert.

K. The inlet and outlet shall be located opposite each other along the axis of maximum dimension. The horizontal distance between the nearest points of the inlet and outlet devices shall be at least four feet.

L. Sanitary tees shall be at least four inches in diameter. Inlet baffles shall be no less than six inches or no more than 12 inches measured from the end of the inlet pipe to the nearest point on the baffle. Outlet baffles shall be six inches measured from beginning of the outlet pipe to the nearest point on the baffle.

M. Access to the septic tank shall be as follows:

(1) There shall be one or more manholes, at a minimum of 20 inches least dimension, and located within six feet of all walls of the tank. The manhole shall extend through the tank cover to a point within 12 inches of finished grade. If the manhole is covered with less than six inches of soil, the cover must be secured to prevent unauthorized access.

(2) There shall be an inspection pipe of at least four inches diameter over both the inlet and outlet devices. The inspection pipe shall extend through the tank cover or the manhole cover and be capped flush or above finished grade. A downward projection of the center line of the inspection pipe shall be directly in line with the center line of the inlet or outlet device.

(3) An inspection pipe at least four inches in diameter must be located between the inlet and outlet baffles for the purpose of evaluating scum and sludge accumulations. The inspection pipe must extend through either the tank cover or manhole cover and must be capped flush with or above finished grade.

N. Compartmentation of single tanks.

(1) Septic tanks larger than 3,000 gallons and fabricated as a single unit shall be divided into two or more compartments.

(2) When a septic tank is divided into two compartments, not less than one-half nor more than two-thirds of the total volume shall be in the first compartment.

(3) When a septic tank is divided into three or more compartments, one-half of the total volume shall be in the first compartment and the other half equally divided in the other compartments.

(4) Connections between compartments shall be baffled so as to obtain effective retention of scum and sludge. The submergence of the inlet and outlet baffles of each compartment shall be as specified in items G and H.

(5) Adequate venting shall be provided between compartments by baffles or by an opening of at least 50 square inches near the top of the compartment wall.

(6) Adequate access to each compartment shall be provided by one or more manholes, at least 20 inches least dimension, and located within six feet of all walls of the tank. The manhole shall extend through the tank cover to a point within 12 inches of finished grade. If the manhole is covered with less than six inches of earth, the cover must be secured to prevent unauthorized access.

O. Multiple tanks.

(1) Where more than one tank is used to obtain the required liquid volume, the tanks shall be connected in series.

(2) Each tank shall comply with all other provisions of subpart 1.

(3) No more than four tanks in series can be used to obtain the required liquid volume.

(4) The first tank shall be no smaller than any subsequent tanks in series.

P. Outlet pipe from septic tank.

(1) The outlet pipe from the septic tank must not be cast iron.

(2) The outlet pipe extending from the septic tank must be of sound and durable construction, not subject to corrosion or decay.

(3) The outlet pipe extending from the septic tank to the undisturbed soil beyond the tank must meet the strength requirements of American Society for Testing and Materials (ASTM), schedule 40 plastic pipe and must be supported in a manner that there is no deflection during the backfilling and subsequent settling of the soil between the edge of the septic tank and the edge of the excavation.

(4) The soil around the pipe extending from the septic tank must be compacted to original density for a length of three feet beyond the edge of the tank excavation.

Subp. 3. Capacity of septic tanks. Capacity of septic tanks:

A. Dwellings. The liquid capacity of a septic tank serving a dwelling shall be based on the number of bedrooms contemplated in the dwelling served and shall be at least as large as the capacities given below (see part 7080.0020, subpart 7):

Number of Bedrooms	Tank Liquid Capacities (gallons)
2 or less	750
3 or 4	1,000
5 or 6	1,500
7, 8 or 9	2,000

# MINNESOTA RULES 1993

1063

## INDIVIDUAL SEWAGE TREATMENT SYSTEMS 7080.0130

For ten or more bedrooms, the septic tank shall be sized as another establishment. See item B.

**B. Other establishments.** The liquid capacity of a septic tank serving an establishment other than a dwelling shall be sufficient to provide a sewage detention period of not less than 36 hours in the tank for sewage flows less than 1,500 gallons per day, but in no instance shall the liquid capacity be less than 750 gallons. For sewage flows greater than 1,500 gallons per day the minimum liquid capacity shall equal 1,125 gallons plus 75 percent of the daily sewage flow. For restaurants and laundromats, twice the liquid capacity shown above must be provided. For laundromats the outlet baffle of the septic tank must be submerged to a depth of 50 percent.

**C. Garbage disposals.** If a garbage disposal unit is installed in a residence or other establishment at any time, septic tank capacity must be at least 50 percent greater than that required in items A and B and either multiple compartments or multiple tanks must be provided.

**D. Pumping of raw sewage.** A sewage pump must not deliver sewage to a one tank system if the pump cycle delivers more than one percent of the liquid capacity of the tank. For systems with multiple tanks, at least two tanks in series must be used, each having at least the liquid capacity specified in this subpart. The volume of sewage delivered in each pump cycle must not exceed five percent of the liquid capacity of the first tank. Owners of multiple tank systems having more than two tanks may increase the volume of the sewage delivered in each pump cycle.

**Subp. 4. Location of septic tanks.** The sewage tank shall be placed so that it is accessible for the removal of liquids and accumulated solids.

The sewage tank shall be placed on firm and settled soil capable of bearing the weight of the tank and its contents.

Sewage tanks shall be set back as specified in Table IV, part 7080.0170, subpart 2, item B.

Sewage tanks shall not be placed in areas subject to flooding or in flood plains delineated by local ordinances adopted in compliance with the "Statewide Standards for Management of Flood Areas of Minnesota" (chapter 6120), or in areas for which regional flood information is available from the DNR, except that in areas where ten year flood information is available from and/or approved by the DNR, sewage tanks may be installed in accordance with all provisions of part 7080.0210, subpart 3, item D.

### **Subp. 5. Maintenance of septic tanks.**

**A.** The owner of any septic tank or the owner's agent shall regularly, but in no case less frequently than every three years, inspect and measure the accumulations of sludge, which includes the settled materials at the bottom of the tank, and the accumulations of scum, which includes grease and other floating materials at the top of the tank. The owner of any septic tank or the owner's agent must arrange for the removal and sanitary disposal of septage from the tank whenever the top of the sludge layer is less than 12 inches below the bottom of the outlet baffle or whenever the bottom of the scum layer is less than three inches above the bottom of the outlet baffle. Removal of septage shall include complete removal of scum and sludge.

**B.** Individual sewage treatment system additives which contain hazardous materials must not be used in individual sewage treatment systems in Minnesota.

**C.** Individual sewage treatment system additives must not be used as a means to reduce the frequency of proper maintenance and removal of septage from the septic tank as specified in item A.

**Subp. 6. Aerobic tanks.** Aerobic tank treatment systems shall comply with the general requirements for sewage tanks set forth in subpart 1, and with the following:

**A.** The treatment system including each individual unit or compartment shall be easily accessible for inspection and maintenance and shall be provided with secured covers.

**B.** The raw sewage flow from the dwelling shall be intercepted by a trash trap prior to its entering the aeration compartment. The trash trap shall have a net holding capacity of not less than 20 percent of the average daily flow. The invert level to the trap shall be above

the liquid level and discharge directly into the trap. The outlet from the trap to the aeration compartment shall be deep baffled or equipped with a tee or long ell.

C. The trash trap shall be readily accessible for inspection and effective cleaning and shall be so constructed as to prevent unauthorized entry.

D. The aeration compartment shall have a minimum holding capacity of 500 gallons or 120 gallons per bedroom, whichever is greater.

E. The method of aeration shall be accomplished by mechanical aeration, diffused air, or both. The method used shall maintain aerobic conditions at all times.

F. The settling compartment shall have a minimum net holding capacity equal to 20 percent of the volume of the aeration compartment. The design shall provide for effective settling and continuous return of settled sludge to the aeration compartment.

G. A minimum one year warranty and an initial two year service contract which specifies regular inspection calls and effluent quality checks shall be provided as a part of the purchase agreement.

H. All other features of the aerobic tanks not specifically mentioned above shall comply with National Sanitation Foundation Standard No. 40 (November 1970).

**Statutory Authority:** *MS s 115.03 subd 1*

**History:** *13 SR 2752*

#### 7080.0150 DISTRIBUTION OF EFFLUENT.

##### Subpart 1. Gravity distribution.

A. Drop boxes or valve boxes must be used to distribute effluent to individual trenches in a soil treatment system unless the necessary elevation differences between trenches for drop boxes cannot be achieved by natural topography or by varying the excavation depths, in which case a distribution box or a valve box may be used. The drop boxes must meet the following standards.

(1) The drop box shall be watertight and constructed of durable materials not subject to corrosion or decay.

(2) The invert of the inlet pipe shall be at least one inch higher than the invert of the outlet pipe to the next trench.

(3) The invert of the outlet pipe to the next trench shall be at least two inches higher than the invert of the outlet pipe of the trench in which the box is located.

(4) When sewage tank effluent is delivered to the drop box by a pump, the pump discharge shall be directed against a wall or side of the box on which there is no outlet.

(5) The drop box shall have a removable cover either flush or above finished grade or covered by no more than six inches of soil.

B. Systems using valve boxes shall comply with the requirements in part 7080.0170, subpart 2, item D. The valve boxes shall meet the standards in subitems (1) to (4).

(1) The valve boxes shall be watertight and constructed of durable materials not subject to corrosion or decay.

(2) The invert of the inlet pipe shall be at least one inch higher than the inverts of the outlet pipes to the trenches.

(3) When sewage tank effluent is pumped to a valve box, either a baffle wall must be installed in the valve box or the pump discharge must be directed against a wall or side of the box on which there is no outlet. The baffle must be secured to the box and extend at least one inch above the crown of the inlet flow line.

(4) The valve box shall have a removable cover either flush or above finished grade or covered by no more than six inches of soil.

C. The distribution boxes must meet the following standards:

(1) The box must be watertight with either a removable cover or a cleanout pipe extending to finished grade and must be constructed of durable materials not subject to corrosion or decay.

(2) The inverts of all outlets must be at the same elevation.

(3) The inlet invert must be either at least one inch above the outlet inverts or be sloped such that an equivalent elevation above the outlet invert is obtained within the last eight feet of the inlet pipe.

# MINNESOTA RULES 1993

1065

## INDIVIDUAL SEWAGE TREATMENT SYSTEMS 7080.0150

(4) Each drain field trench line must be connected separately to the distribution box and must not be subdivided.

(5) When sewage tank effluent is delivered to the distribution box by pump, either a baffle wall must be installed in the distribution box or the pump discharge must be directed against a wall or side of the box on which there is no outlet. The baffle must be secured to the box and must extend at least one inch above the crown of the inlet flow line.

### D. Distribution pipes.

(1) Distribution pipes used in trenches or beds for gravity distribution must be at least four inches in diameter and must be constructed of sound and durable material not subject to corrosion or decay or to loss of strength under continuously wet conditions.

(2) Perforated pipe used for sewage distribution pipes must have one or more rows of holes of no less than one-half inch in diameter spaced no more than 40 inches apart. Holes must be spaced to prevent failure due to loads. Distribution pipes must have a load bearing capacity of not less than 1,000 pounds per lineal foot.

(3) The distribution pipes for gravity distribution must be laid level or on a uniform slope away from the distribution device of no more than four inches per 100 feet.

(4) Gravity distribution pipes in beds must be uniformly spaced no more than five feet apart and not more than 30 inches from the side walls of the bed.

(5) Other devices such as corrugated tubing wrapped with a permeable synthetic material or a chambered trench or bed may be used to distribute sewage tank effluent over the soil treatment area upon approval of the permitting authority.

### Subp. 2. Pressure distribution.

A. Pressure distribution must be used for the following soil treatment systems:

(1) all mound systems; and

(2) systems where the soil percolation rate is 0.1 to five minutes per inch if the effluent is pumped to a seepage bed or to trenches that are all at the same elevation.

B. Distribution pipes used for pressure distribution must be constructed of sound and durable material not subject to corrosion or decay or to loss of strength under continuously wet conditions.

C. All pipes and associated fittings used for pressure distribution must be properly joined together. The pipe and connections must be able to withstand a pressure of at least 40 pounds per square inch.

D. Perforations must be no smaller than 3/16 inch diameter and no larger than one-quarter inch diameter. The number of perforations, perforation spacing, and pipe size for pressure distribution laterals must be as shown in table I. The friction loss in any individual perforated lateral must not exceed 20 percent of the average pressure head on the perforations.

Table I

Maximum Allowable Number of One-Fourth Inch Diameter, or Smaller, Perforations Per Lateral

Perforation Spacing in feet	Pipe Diameter, Nominal and Inside			
	1"	1-1/4"	1-1/2"	2"
2.5	8	14	18	28
3	8	13	17	26
3.3	7	12	16	25
4	7	11	15	23
5	6	10	14	22

E. Perforation holes must be drilled straight into the pipe and not at an angle. The perforated pipe laterals must be installed level with the perforations downward.

F. Laterals must be spaced no further than 60 inches apart and must be spaced no further than a horizontal distance of 30 inches from the bottom edge of a drainfield rock layer.

G. Laterals must be connected to a header or manifold pipe that is of a diameter such that the friction loss in the header or manifold will be no greater than five percent of the average head at the perforations. The header or manifold pipe must be connected to the supply pipe from the pump.

H. Perforated laterals must be designed and installed in such a way that no perforations are located closer than 12 inches from the edge of the drainfield rock.

**Statutory Authority:** *MS s 115.03 subd 1*

**History:** *13 SR 2752*

#### 7080.0160 DOSING OF EFFLUENT.

Subpart 1. **Dosing chamber.** A dosing device is not necessary in all situations but, where used, shall comply with the following requirements:

A. The dosing chamber shall be watertight and constructed of sound and durable materials not subject to excessive corrosion or decay.

B. There shall be one or more manholes, at least 20 inches least dimension and preferably located directly above the dosing device. The manhole shall extend through the dosing chamber cover to final grade and shall be so constructed as to prevent unauthorized entry.

C. The size of the effluent dose shall be determined by design of the soil treatment unit but in no case shall the dosing chamber be sized to provide a dose of less than 75 gallons.

Subp. 2. **Dosing devices for gravity distribution.** Dosing devices for gravity distribution:

A. Where a dosing device is employed, a pump or siphon shall deliver the dose to the soil treatment unit for gravity distribution over the soil treatment area.

B. For dwellings, the dosing device shall discharge at least 600 gallons per hour but no more than 2,700 gallons per hour.

C. For other establishments, the dosing device should discharge at a rate at least ten percent greater than the water supply flow rate but no faster than the rate at which effluent will flow out of the distribution device.

D. If the dosing device is a siphon, a maintenance inspection shall be made every six months by the owner or the owner's agent. The siphon shall be maintained in proper operating condition.

E. If the dosing device is a pump, it shall be cast iron or bronze fitted and with stainless steel screws or constructed of other sound, durable, and corrosion-resistant materials.

F. Where the soil treatment area is at a higher elevation than the pump, sufficient dynamic head shall be provided for both the elevation difference and friction loss.

G. Where the dosing device is a pump, an alarm device shall be installed to warn of pump failure.

Subp. 3. **Dosing devices for pressure distribution.** Dosing devices for pressure distribution:

A. The dosing device shall be a pump which is cast iron or bronze fitted and with stainless steel screws or constructed of sound, durable, and corrosion-resistant materials.

B. The pump discharge capacity shall be based upon the perforation discharges for an average head of 1.0 feet for residential systems and 2.0 feet for other establishments. Perforation discharge will be determined by the following formula:

$$Q = 19.65 cd^2h^{1/2}$$

where: Q = discharge in gallons per minute

c = 0.60 = coefficient of discharge

d = perforation diameter in inches

h = head in feet.

C. The pump discharge head shall be at least five feet greater than the head required to overcome pipe friction losses and the elevation difference between the pump and the distribution device.

D. The quantity of effluent delivered for each pump cycle shall be no greater than 25 percent of one day's sewage flow.

# MINNESOTA RULES 1993

1067

## INDIVIDUAL SEWAGE TREATMENT SYSTEMS 7080.0170

E. An alarm device shall be installed to warn of pump failure.

F. A siphon will not be allowed as a dosing device to deliver effluent to a pressure distribution system.

G. The dosing chamber for a pressure distribution system shall either include a two pump system or shall be sized to include a minimum reserve capacity of 75 percent of the daily design flow.

**Statutory Authority:** *MS s 115.03 subd 1*

**History:** *13 SR 2752*

### 7080.0170 FINAL TREATMENT AND DISPOSAL.

Subpart 1. **In general.** Final treatment and disposal of all sewage tank effluent shall be by means of soil treatment and disposal.

#### Subp. 2. **Standard system.**

##### A. Sizing:

(1) The required soil treatment area shall be determined by the daily sewage flow and the percolation rate of the soil.

(2) Acceptable methods for estimating sewage flow for dwellings are given in Table II. The minimum daily sewage flow estimated for any dwelling shall provide for at least two bedrooms. For multiple residential units, the estimated daily sewage flow shall consist of the sum of the flows of each individual unit.

Table II. Sewage flow (gallons per day).

Number of Bedrooms	Classification of Dwelling*			
	I	II	III	IV
2	300	225	180	—
3	450	300	218	—
4	600	375	256	—
5	750	450	294	—
6	900	525	332	—

\*Table II is based on the following formulas:

Classification I: Sewage Flow = 150 x (No. of Bedrooms)

The total floor area of the residence divided by the number of bedrooms is more than 800 square feet per bedroom, or more than two of the following water-use appliances are installed: automatic washer, dishwasher, water softener, garbage disposal, or self-cleaning humidifier in furnace.

Classification II: Sewage Flow = 75 x (No. of Bedrooms + 1)

More than 500 square feet of total residence floor area per bedroom and no more than two of the water-use appliances listed in Classification I.

Classification III: Sewage Flow = 66 + 38 x (No. of Bedrooms + 1)

Less than 500 square feet of total residence floor area per bedroom and no more than two of the water-use appliances listed in Classification I.

Classification IV: Classification I, II, or III but with no toilet wastes discharged into the sewage system. If a greywater system is employed pursuant to part 7080.0210, subpart 4, item B, Appendix A, estimated sewage flow shall equal 60 percent of the amount provided in column I, II, or III of Table II.

(3) For other establishments, the daily sewage flow shall be determined as provided in part 7080.0020, subpart 34.

(4) Table III gives the required trench bottom area assuming six inches of drainfield rock below the distribution pipe. The required bottom area may be reduced, for trenches only, by the following percentages: 20 percent for 12 inches of drainfield rock below the distribution pipe; 34 percent for 18 inches; and 40 percent for 24 inches. Unless pressure distribution is used, all seepage bed bottom areas must be 1.5 times the soil treatment areas required in Table III.

# MINNESOTA RULES 1993

Table III

Percolation Rate (Minutes per inch)	Required Soil Treatment Area in Square Feet of Trench Bottom (Per Gallon of Sewage Flow per Day)
Faster than 0.1*	—
0.1 to 5**	0.83****
6 to 15	1.27
16 to 30	1.67
31 to 45	2.00
46 to 60	2.20
61 to 120***	—
Slower than 120*****	—

\*See items F and G for special requirements for these soils.

\*\*See items F and G for special requirements for these soils.

\*\*\*See items E and G for special requirements for these soils.

\*\*\*\*For soils having more than 50 percent of very fine sand by weight, plus fine sand having a particle size range of 0.05 millimeters (sieve size 270) to 0.25 millimeters (sieve size 60), the required soil treatment area is 1.67 square feet per gallon of sewage flow per day.

\*\*\*\*\*See item E and part 7080.0210, subpart 5, item A, for special requirements for these soils.

**B. Location:**

(1) On slopes in excess of 12 percent, the soil profile shall be carefully evaluated in the location of the proposed soil treatment system and downslope to identify the presence of layers with different permeabilities that may cause sidehill seepage. In no case shall a trench be located within 15 feet of where such a layer surfaces on the downslope.

(2) Bed construction shall be limited to areas having natural slopes of less than six percent.

(3) Soil treatment systems shall be located as specified in Table IV.

Table IV. Minimum setback distances (feet).

Feature	Sewage Tank	Soil Treatment Area
Water Supply well less than 50 feet deep and not encountering at least ten feet of impervious material	*	*
Any other water supply well or buried water suction pipe	*	*
Buried pipe distributing water under pressure	*	*
Buildings	10	20
Property Lines	10	10
The Ordinary High Water Level of Public Waters	**	**

\*Setbacks from water supply wells and buried water pipes are governed by chapter 4725.

\*\*Setbacks from lakes, rivers, and streams are governed by chapters 6105 and 6120.



# MINNESOTA RULES 1993

1069

## INDIVIDUAL SEWAGE TREATMENT SYSTEMS 7080.0170

(4) Soil treatment areas shall not be placed in areas subject to flooding or in flood plains delineated by local ordinances adopted in compliance with the "Statewide Standards and Criteria for Management of Flood Plain Areas of Minnesota" (chapter 6120), or in areas for which regional flood information is available from the DNR, except that in areas where ten year flood information is available from and/or approved by the DNR, soil treatment systems may be installed in accordance with the provisions of Appendix A, part 7080.0210, subpart 3, item D.

(5) Soil treatment areas of individual sewage treatment systems that are designed to treat an estimated daily sewage flow greater than 3,000 gallons per day must be separated from other similarly sized systems by at least 300 feet.

### C. Design and construction:

(1) The bottom of trenches and beds shall be at least three feet above the water table or bedrock.

(2) The trenches shall be not less than 18 inches nor more than 36 inches wide. Any excavation wider than 36 inches shall be considered a bed. No bed may be wider than 25 feet and parallel beds must not be located closer than ten feet apart.

(3) Trenches and beds shall be not more than 100 feet in length.

(4) The bottom of the trench or bed excavation shall be level.

(5) The bottom and sides of the soil treatment system to the top of the drainfield rock shall be excavated in such a manner as to leave the soil in a natural, unsmearred, and uncompacted condition. Excavation shall be made only when the soil moisture content is at or less than the plastic limit.

(6) When the percolation rate is slower than 15 minutes per inch, excavation shall be by backhoe or other means that allow the equipment wheels or tracks to remain on the surface soil. Excavation equipment or other vehicles shall not be driven on the soil treatment area.

(7) There shall be a layer of at least six but no more than 24 inches of drainfield rock in the bottom of the trenches and beds.

(8) Where disposal trenches are constructed within ten feet of trees six inches or larger in diameter, or dense shrubbery, or where it can reasonably be anticipated that such vegetation will be present during the expected life of the system, at least 12 inches of drainfield rock shall be placed beneath the distribution pipe.

(9) The drainfield rock shall completely encase the top and sides of the distribution pipes to a depth of at least two inches. The top of the drainfield rock in trenches, beds, and mounds must be level in all directions.

(10) The drainfield rock must be covered with either a permeable synthetic fabric or a four-inch compacted layer of hay or straw covered with untreated building paper. Where a drop box distribution system is used to fill a trench to within two inches of the top of the drainfield rock, a permeable synthetic fabric must be used to cover the drainfield rock.

(11) The trenches or beds shall be backfilled and crowned above finished grade to allow for settling. The top six inches of soil shall have the same texture and density as the adjacent soil.

(12) The minimum depth of cover over the distribution pipes shall be at least eight inches. The maximum depth of cover over the distribution pipes shall be no more than 36 inches and preferably no more than 24 inches.

(13) A grass cover shall be established by the owner or the owner's agent over the soil treatment system.

(14) A vertical inspection pipe at least 1-1/2 inches in diameter must be installed in each drainfield rock layer of every trench or seepage bed. The inspection pipe must be located at an end opposite from where the sewage tank effluent enters the rock layer. The inspection pipe must have 3/8 inch or larger perforations spaced vertically no more than six inches apart. At least two perforations must be located in the rock layer. The inspection pipe must extend to the bottom of the rock layer and must be capped flush with or above finished grade.

### D. Dual field systems:

(1) Dual field systems shall be used only where the percolation rate is slower than five minutes per inch.

(2) Dual field systems shall be sized, designed, and constructed as set forth above for standard systems except as follows:

(a) The soil treatment area shall be divided into two or more parts.

(b) Alternating soil treatment areas shall each be connected to a valve box outlet.

(3) A part of the soil treatment area shall be used no more than one year unless inspection of the effluent level indicates that a longer duration can be used.

#### E. Slowly permeable soils.

(1) Excavation for the purpose of constructing a soil treatment system must not be made in any soil layer having a percolation rate slower than 120 minutes per inch.

(2) Excavation for the purpose of constructing a soil treatment system must not be made in a soil layer having a percolation rate slower than 60 minutes per inch unless the moisture content is lower than the plastic limit of the soil.

(3) Drainfield rock must not be placed in contact with original soil having a percolation rate slower than 60 minutes per inch.

(4) Where the percolation rate of the original soil is slower than 60 minutes per inch, at least 12 inches of fill material having a texture defined as sand must be placed between the drainfield rock and the original soil along the excavation bottom.

(5) Construction equipment wheels or tracks must not be placed in contact with the bottom of the excavation during the construction of a soil treatment system in soils having a percolation rate slower than 15 minutes per inch.

(6) The size of the soil treatment system must be based on an acceptance rate of 0.24 gallons per square foot, which is equivalent to a sizing factor of 4.2 square feet per gallon per day.

#### F. Rapidly permeable soils.

(1) Drainfield rock for a soil treatment unit must not be placed in contact with original soil having a percolation rate faster than one-tenth minute per inch.

(2) For coarse soils having a percolation rate faster than one-tenth minute per inch, at least 12 inches of loamy sand textured soil having a percolation rate between six and 15 minutes per inch at the original site must be placed between the drainfield rock and the coarse soil along the excavation bottom and sidewalls. The size of the soil treatment system must be based on the required treatment area for a soil having a percolation rate of 16 to 30 minutes per inch as specified in item A, subitem (4).

(3) For soils with percolation rates between one-tenth and five minutes per inch, at least one of the following treatment techniques must be used:

(a) distribute the sewage tank effluent by pressure flow over the treatment area as specified in part 7080.0150, subpart 2;

(b) divide the total soil treatment area into at least four equal parts connected serially; or

(c) provide at least 12 inches of loamy sand textured soil with a percolation rate between six and 15 minutes per inch in situ between the drainfield rock and the coarse soil. Trenches must be used with this liner system. The size of the soil treatment system must be based on the required treatment area for a soil having a percolation rate between 16 to 30 minutes per inch as specified in item A, subitem (4), Table III.

#### G. Mounds.

(1) Mounds must be constructed on original soils so that there is at least 36 inches of separation between the bottom of the drainfield rock layer and limiting soil characteristics as defined in part 7080.0020, subpart 41.

(2) There must be at least 12 inches of original soil with a percolation rate faster than 120 minutes per inch above the limiting soil characteristics as defined in part 7080.0020, subpart 41.

(3) Where the original soil has a depth of at least 12 inches to the water table as the limiting soil characteristic but has a percolation rate of five minutes per inch or faster, a

# MINNESOTA RULES 1993

1071

## INDIVIDUAL SEWAGE TREATMENT SYSTEMS 7080.0170

layer of at least 12 inches of loamy sand textured soil with a percolation rate between six and 15 minutes per inch at the original site must be placed before placing the clean sand layer of the mound. The required absorption width must be determined for a soil having a percolation rate between 16 and 30 minutes per inch as specified in subitem (5), Table V.

(4) If original soil conditions do not exist on a site proposed for a mound, as defined in part 7080.0020, subpart 24, the site is unsuitable for a mound.

(5) The allowable absorption area loading rate must be determined according to Table V by the percolation rate of the 12 inches of original or fill soil immediately under the sand layer.

Table V

Percolation rate of original soil under sand layer, minutes per inch	Allowable absorption area loading rate	
	gallons per day per square foot	square feet per gallon per day
6 to 15	0.79	1.27
16 to 30	0.60	1.67
31 to 45	0.50	2.00
46 to 60	0.45	2.20
61 to 120	0.24	4.20

(6) The required absorption width of mounds constructed on ground sloping from zero to 2.9 percent must include the width of the rock layer plus a distance measured between the outer edges of the upslope and the downslope banks. The required absorption width for mounds constructed on ground sloping between three and 12 percent must include the width under the drainfield rock layer plus a portion of the width of the downslope bank.

(7) Mounds may be located on natural slopes exceeding 12 percent if the absorption area is designed to be at least 25 percent larger than that required in Table V.

(8) The bottom area of the drainfield rock layer must be sized on the basis of 0.83 square feet per gallon of waste per day.

(9) The width of the drainfield rock layer in a single bed must not exceed ten feet.

(10) A rubber tired tractor may be used for plowing or discing but must not be driven on the absorption area after the surface preparation is completed. A crawler or track type tractor must be used for mound construction where the soil percolation rate is slower than 15 minutes per inch.

(11) The discharge pipe from the pump to the mound area must be installed before soil surface preparation. The trench must be carefully backfilled and compacted to prevent seepage of effluent.

(12) All vegetation in excess of four inches in length and dead organic debris must be removed from the surface of the total area selected for the mound, including the area under the banks. The total area must be roughened by plowing to a depth of at least eight inches or the sod layer broken and roughened by backhoe teeth. Furrows must be thrown uphill and there must be no dead furrow under the mound. The soil must be plowed or roughened when the moisture content of a fragment eight inches below the surface is below the plastic limit. The soil under a mound, including the area under the banks, must not be roughened by rototilling or pulverizing. In soils having percolation rates faster than 15 minutes per inch (sandy loam) in the top eight-inch depth, discing may be used for surface preparation as a substitute for plowing. Mound construction must proceed immediately after surface preparation is completed. The original soil must not be excavated or moved more than one foot from its original location during soil surface preparation.

(13) A minimum of 12 inches of soil defined as sand must be placed where the drainfield rock is to be located. This sand must be placed by using a construction technique that minimizes compaction. If the sand is pushed into place, a crawler tractor with a blade or unloaded bucket must be used to push the sand into place. At least six inches of sand must be kept beneath equipment to minimize compaction of the plowed layer. When placing sand

with a backhoe that has rubber tires, the tractor must not drive over the drainfield rock or banks of the mound. The sand layer upon which the drainfield rock is placed must be level.

On slopes of three percent or greater, the long axis of the level drainfield rock layer must not diverge up or down the slope by more than 12 inches of elevation from the natural contour line. The depth of the sand layer along the upper edge of the level drainfield rock layer must not vary by more than 12 inches.

On slopes of three percent or greater, and where the percolation rate in the top foot of original soil is in the 61 to 120 minutes per inch range, mounds must not be located where the ground surface contour lines directly below the long axis of the drainfield rock layer represent a swale or draw, unless the contour lines have a radius of curvature greater than 100 feet. Mounds must never be located in swales or draws where the radius of curvature of the contour lines is less than 50 feet.

(14) A depth of at least nine inches of drainfield rock must be placed over the bed area below the distribution pipe.

(15) Distribution of effluent over the drainfield rock layer must be by perforated pipe under pressure.

(16) The drainfield rock shall completely encase the top and sides of the distribution pipes to a depth of at least two inches. The top of the drainfield rock must be level in all directions.

(17) The drainfield rock must be covered with either a permeable synthetic fabric or a four-inch layer of hay or straw covered with untreated building paper.

(18) Construction vehicles must not be allowed on the drainfield rock until backfill is placed.

(19) Sandy loam soil must be placed on the drainfield rock to a depth of one foot in the center of the mound and to a depth of six inches at the sides.

(20) A maximum of two ten-foot wide beds may be installed side by side in a single mound if the original soil percolation rate is between five and 60 minutes per inch to a depth of at least 24 inches below the sand layer. The beds must be separated by four feet of clean sand.

(21) When two beds are installed side by side the sandy loam fill must be 18 inches deep at the center of the mound and six inches deep at the sides.

(22) Six inches of top soil must be placed on the fill material over the entire area of the mound.

(23) A grass cover must be established over the entire area of the mound.

(24) Shrubs must not be planted on the top of the mound. Shrubs may be placed at the foot and side slopes of the mound.

(25) The side slopes on the mound must not be steeper than three to one.

(26) Whenever mounds are located on slopes, a diversion must be constructed immediately upslope from the mound to intercept and direct runoff.

(27) A pump must be used as specified in part 7080.0160, subpart 3.

(28) A vertical inspection pipe at least 1-1/2 inches in diameter must be installed in each drainfield rock layer of every mound. The inspection pipe must have three-eighths inch or larger perforations spaced vertically no more than six inches apart. At least two perforations must be located in the rock layer. The inspection pipe must extend to the bottom of the rock layer and must be capped flush with or above finished grade.

**Statutory Authority:** *MS s 115.03 subd 1*

**History:** *13 SR 2752*

#### **7080.0180 ALTERNATIVE SYSTEMS.**

Where limiting soil characteristics exist, special systems of sewage treatment and disposal, including but not limited to those in Appendix A, part 7080.0210, may be employed provided:

A. reasonable assurance of performance of such system is presented to the permitting authority;

# MINNESOTA RULES 1993

1073

## INDIVIDUAL SEWAGE TREATMENT SYSTEMS 7080.0210

B. the engineering design of such system is first approved by the permitting authority;

C. there is no discharge to the ground surface or to surface waters;

D. treatment and disposal of wastes is in such a manner so as to protect the public health and general welfare; and

E. such systems comply with all applicable requirements of these standards and with all local codes and ordinances.

**Statutory Authority:** *MS s 115.03 subd 1*

### 7080.0190 SEVERABILITY.

If any provision of these standards or the application thereof to any person or circumstances is held to be invalid, such invalidity shall not affect other provisions of these standards or application of any other part of these standards which can be given effect without application of the invalid provision. To this end the provisions of all sections, subsections, or subdivisions herein and the various applications thereof are declared to be severable.

**Statutory Authority:** *MS s 115.03 subd 1*

### 7080.0200 VARIANCE.

In any cases where a permit or review is required by a state agency and, upon application of the responsible person or persons, that agency finds that by reason of exceptional circumstances the strict enforcement of any provision of these standards would cause undue hardship, that disposal of the sewage, industrial waste, or other waste is necessary for the public health, safety, or welfare, or that strict conformity with the standards would be unreasonable, impractical, or not feasible under the circumstances, the agency in its discretion may permit a variance upon conditions as it may prescribe for prevention, control, or abatement of pollution in harmony with the general purpose of these standards and the intent of applicable state and federal laws.

**Statutory Authority:** *MS s 115.03 subd 1*

**History:** *13 SR 2752*

### 7080.0210 APPENDIX A: ALTERNATIVE SYSTEMS.

**Subpart 1. General.** The intent of this appendix is to provide standards for the design, location, installation, use, and maintenance of alternative sewage treatment systems in areas of limiting soil characteristics, or where a standard system cannot be installed or is not the most suitable treatment. Where such systems are employed, they shall comply with all local codes and ordinances, and be subject to timely inspections to assure adherence to specifications.

**Subp. 2. Adoption and use.** Where parts 7080.0010 to 7080.0210 are administered by a municipality, those municipalities may adopt this appendix, in whole or in part, as part of a local code or ordinance. Nothing in parts 7080.0010 to 7080.0210 or this appendix, however, shall require the adoption of any part of this appendix as local ordinance or code. Further, nothing in parts 7080.0010 to 7080.0210 or this appendix shall require municipalities to allow the installation of any system in this appendix.

This appendix defines the minimum requirements for alternative systems serving establishments or facilities licensed or otherwise regulated by the state of Minnesota or this agency pursuant to part 7080.0030. ◦

#### **Subp. 3. Class I alternatives, modified standard systems.**

A. Extreme caution and careful planning shall be employed wherever limiting characteristics including, but not limited to, water table or bedrock exist within two feet of the original ground surface.

B. Fluctuating ground water.

(1) Where natural drainage will not provide three feet of separation between the bottom of the soil treatment area and the highest known or calculated level of the water table, agricultural drain tile may be used to intercept or lower the seasonal high water table, except within shorelands of public waters. There shall be at least ten feet of undisturbed soil between the sidewall of the soil treatment unit and the agricultural drain tile.

(2) Within shorelands of public waters, agricultural drain tile may be used to intercept the seasonal high water table provided the ground water table has a slope of at least two feet per hundred feet toward the public water and provided the drain tile are installed upslope of the soil treatment system. There shall be at least 20 feet of undisturbed soil between the sidewall of the soil treatment unit and the agricultural drain tile.

(3) In all cases the greatest practicable vertical separation distance from the water table shall be provided.

C. Bedrock proximity. In no case shall drainfield rock of the soil treatment system be placed closer than three feet to creviced bedrock or to consolidated permeable bedrock. When all horizons of the original soil profile have percolation rates slower than 60 minutes per inch, drainfield rock of the soil treatment system shall be placed no closer than seven feet to consolidated impermeable bedrock. A maximum depth of 24 inches of sand may be used under the drainfield rock. Where additional fill is required to achieve the required separation distance, a soil having a percolation rate between five and 45 minutes per inch (loamy sand to silt loam) 12 months after placement shall be used. If it is not possible to allow the soil to settle for 12 months after placement, mechanical methods may be used to settle the fill to within ten percent of its density at the original site.

D. Floodplain areas.

(1) The soil treatment area shall be a trench system with at least 12 inches of drainfield rock below the distribution pipe. There shall be no pipe or other installed opening between the drainfield rock and the soil surface.

(2) The trench system shall be located on the highest feasible area of the lot and shall have location preference over all other improvements except the water supply well. The bottom of the trench shall be at least as high as the elevation of the ten-year flood. The sewage tank may be located so as to provide gravity flow to the soil treatment area.

(3) If a pumping station is used to move effluent from the sewage tank to the drain field, provisions shall be made to prevent the pump from operating when inundated with flood waters.

(4) When fill is needed to raise the elevation of the soil treatment area, a mound system may be used with the following additional requirement: The elevation of the mound shall be such that the elevation of the bottom of the rock layer shall be at least one-half foot above the ten-year flood elevation. Inspection wells shall not be installed unless the top of the mound is above the elevation of the regional flood.

(5) When the top of the sewage tank is inundated, the dwelling must cease discharging sewage into it. This may be accomplished by either temporarily evacuating the structure until the system again becomes functional, or by diverting the sewage into a holding tank sized and installed according to the requirements below.

(6) The building sewer shall be designed to prevent backflow of liquid into the building when the system is inundated. If a holding tank is utilized, the building sewer shall be designed to permit rapid diversion of sewage into the holding tank when the system is inundated.

(7) If a holding tank is utilized for a dwelling, its liquid capacity shall be equal to 100 gallons times the number of bedrooms times the number of days between the ten-year stage on the rising limb of the regional flood hydrograph and the ten-year stage on the falling limb of the hydrograph, or 1,000 gallons, whichever is greater. For other establishments, storage equal to at least five times the estimated daily flow must be provided.

(8) Whenever the water level has reached a stage above the top of the sewage tank, the tank shall be pumped to remove all solids and liquids after the flood has receded before use of the system is resumed.

Subp. 4. **Class II alternatives, reduced area systems.**

A. Aerobic tanks. No additional reduction in soil treatment area shall be allowed with the use of an aerobic treatment tank.

B. Separate toilet waste and greywater systems.

(1) General. A toilet waste treatment device shall be used in conjunction with a greywater system. In all cases, only toilet wastes shall be discharged to toilet waste treat-

# MINNESOTA RULES 1993

1075

## INDIVIDUAL SEWAGE TREATMENT SYSTEMS 7080.0210

ment devices. Greywater or garbage shall not be discharged to the device except as specifically recommended by a manufacturer.

### (2) Toilet waste treatment devices.

(a) Toilet waste treatment devices shall be considered as one of two types: I, privies; and II, other devices, including, but not limited to, incinerating, composting, biological, chemical, recirculating, or holding toilets.

(b) Type I, privies. Pit privies shall not be installed where the bottom of the pit is less than three feet above the water table. A vault privy shall be used in areas of high ground water. The vault of a vault privy shall be constructed in the same manner as a septic tank. See part 7080.0130, subpart 1.

Privies shall be set back from surface waters the same distance as required for buildings and from property lines and water supply wells the same distance as required for soil treatment areas.

Pits or vaults shall be of sufficient capacity for the residence they serve, but shall have at least 50 cubic feet of capacity.

The sides of the pit shall be curbed to prevent cave-in.

The superstructure shall be constructed so as to be easily cleaned, and it shall be insect proof. The door and seat shall be self-closing. All openings including vent openings, shall be screened.

Privies shall be adequately vented.

When the pit is filled to within one foot of the top the solids shall be removed or a new pit shall be constructed. The abandoned pit shall be filled with clean earth and slightly mounded to allow for settling. Removed solids shall be disposed of by land application in accordance with agency guidelines for septage disposal and all local ordinances and codes.

(c) Type II, other devices. Other devices may be used where reasonable assurance of performance is provided.

All type II devices shall be vented.

All electric, gas, and water connections to a type II device shall conform to all local ordinances and codes.

Operation and maintenance of all type II devices shall follow the manufacturer's recommendations.

(d) All materials removed from a type I or II toilet waste treatment device, including but not limited to, ashes, compost, and all solids and liquids shall be disposed of in a public sewage system or by land application in accordance with the agency's septage disposal guidelines and all local ordinances and codes.

### (3) Greywater system.

(a) Plumbing. The drainage system in new systems shall be based on a pipe diameter of two inches to prevent installation of a water flush toilet. There shall be no openings or connections to the drainage system, including floor drains, larger than two inches in diameter. For repair or replacement of an existing system, the existing drainage system may be used.

Toilets or urinals of any kind shall not be connected to the drainage system. Toilet waste or garbage shall not be discharged to the drainage system.

Garbage grinders shall not be connected to the drainage system.

(b) Building sewer. The building sewer shall meet all requirements of part 7080.0120 except that the building sewer for a greywater system shall be at least two inches in diameter.

(c) Sewage tank. Greywater septic tanks shall meet all requirements of part 7080.0130, subpart 1, except that the liquid capacity of a greywater septic tank serving a dwelling shall be based on the number of bedrooms contemplated in the dwelling served and shall be at least as large as the capacities given in table A-1. See parts 7080.0020, subpart 7, and 7080.0090.

Table A-1

Number of Bedrooms	Tank Liquid Capacity (gallons)
2 or less or hand pump	300
3 or 4	500
5 or 6	750
7, 8 or 9	1,000

For ten or more bedrooms or other establishments, the greywater septic tank shall be sized as for any other establishment (see part 7080.0130, subpart 3, item B) except that the minimum liquid capacity shall be at least 300 gallons.

Greywater aerobic tanks shall meet all requirements of part 7080.0130, subpart 6.

(d) Distribution and dosing. Distribution and dosing of greywater shall meet all requirements of parts 7080.0150 and 7080.0160.

(e) Final treatment and disposal. Standard system. A standard greywater system shall meet all requirements of part 7080.0170.

Alternative system. A greywater mound system shall meet all requirements of part 7080.0170, subpart 2, item G.

C. Seasonal use. Where a commercial establishment is occupied or used for less than 180 days per year and less than 120 days consecutively, the maximum daily sewage flow shall be determined and the average daily sewage flow shall be computed by dividing the total annual estimated or measured sewage flow by 365 days. The size of the soil treatment system shall be based on the average daily sewage flow and the areas specified in table III set forth in part 7080.0170, subpart 2. All other requirements of soil treatment system construction shall be followed.

The maximum daily sewage flow shall be used to determine sewage tank size for other establishments. There shall be no reduction in the size of sewage tanks for seasonal use.

In no case shall a seasonal use establishment be converted to full time use until the soil treatment system meets the size requirements of table III set forth in part 7080.0170, subpart 2.

**Subp. 5. Class III: alternatives, advanced alternative system.**

A. Mounds may be allowed on original soils with percolation rates slower than 120 minutes per inch if the following special design requirements, in addition to those listed in part 7080.0170, subpart 2, item G, are used:

- (1) the width of the drainfield rock layer must not exceed five feet;
- (2) beds shall not be installed side by side; and
- (3) all vegetation in excess of two inches in length must be removed from the total area under the banks.

**B. Collector systems.**

(1) In general. Where site or soil conditions do not allow for final treatment and disposal on an individual lot, a system where a soil treatment system is located on another lot or lots may be employed, where approved by the municipality.

Plans and specifications shall comply with local ordinances on such issues as zoning, joint ownership of land, joint maintenance responsibilities, easements, and other considerations and shall be approved by the municipality.

**(2) Design.**

(a) The size of a common soil treatment system for two to four dwellings connected to a single drainfield shall be based on the sum of the areas required for each residence. Where three or more dwellings are connected to a single drainfield, Classification I dwellings may be considered as Classification II dwellings by the owner for the purpose of determining the flow required for the size of the common soil treatment system. Classifications and flow rates are found in Table II, contained in part 7080.0170, subpart 2, item A, subitem (2).

(b) The system shall be designed with each residence having a sewage tank or with a common sewage tank. In the case of a common tank, the capacity of the tank



# MINNESOTA RULES 1993

1077

## INDIVIDUAL SEWAGE TREATMENT SYSTEMS 7080.0210

shall be sized according to part 7080.0130, subpart 3, item B, and shall be compartmented if in a single tank.

(c) Sewer systems shall be designed on an estimated average daily flow for dwellings based on table II, set forth in part 7080.0170, subpart 2, plus estimated flows from other establishments.

(d) The sewer for systems with common sewage tanks shall be so constructed to give mean velocities, when flowing full, of not less than two feet per second. The sewer for systems with individual sewage tanks shall be so constructed and designed to hydraulically conduct the flow for which they were designed. In no case shall a gravity sewer be less than four inches in diameter.

(e) Infiltration or exfiltration shall not exceed 200 gallons per inch of pipe diameter per mile per day.

(f) Cleanouts, brought flush with or above finished grade, shall be provided wherever a common sewer joins an individual building sewer or piping from an individual sewer tank, or every 100 feet, whichever is less, unless manhole access is provided.

(g) There shall be no physical connection between sewers and water supply systems. Sewers shall be set back from water supply systems and piping as required for building sewers. Where it is not possible to obtain proper separation distances, the sewer connections shall be watertight and pressure tested.

(h) Pump stations shall be watertight.

(i) Pump stations shall have manholes flush with or above finished grade for cleaning and maintenance.

(j) Manhole covers shall be so constructed as to prevent unauthorized entry.

(k) Pumps and pump stations shall be sized to handle peak flows.

(l) An alarm system shall be provided for all pumping stations to warn of pump failure, overflow, or other malfunction.

(3) Maintenance. All persons using a common drain field system shall assure, by contract with maintenance personnel or other equivalent means, that the system will be adequately maintained throughout its useful life. The system so maintained includes, but is not limited to, common drain fields, common sewage tanks, common pumps, common pump stations, common sewers, and all individual tanks connected to the common system.

C. Other systems. Where unusual conditions exist, special systems of treatment and disposal other than those specifically mentioned in items A and B, may be employed provided:

(1) reasonable assurance of performance of the system is presented to the permitting authority;

(2) the engineering design of the system is first approved by the permitting authority;

(3) there is no discharge to the ground surface or to surface waters;

(4) treatment and disposal of wastes is in such a manner so as to protect the public health and general welfare;

(5) the systems comply with all applicable requirements of these standards and with all local codes and ordinances.

### Subp. 6. Class IV alternatives, holding tanks: Holding tanks:

A. Holding tanks may be allowed only as replacements for existing nonconforming systems or on existing parcels or lots as of the date of the enactment of these standards and only where it can conclusively be shown that a standard, Class I, Class II, Class III, or mound system cannot be feasibly installed.

B. A holding tank shall be constructed of the same materials and by the same procedures as those specified for watertight septic tanks.

C. A cleanout pipe of at least six inches diameter shall extend to the ground surface and be provided with seals to prevent odor and to exclude insects and vermin. A manhole of at least 20 inches least dimension shall extend through the cover to a point within 12 inches,

# MINNESOTA RULES 1993

## 7080.0210 INDIVIDUAL SEWAGE TREATMENT SYSTEMS

1078

but no closer than six inches below finished grade. The manhole cover shall be covered with at least six inches of earth.

D. The tank shall be protected against flotation under high water table conditions. This shall be achieved by weight of tank, earth anchors, or shallow bury depths.

E. For a dwelling the size shall be 1,000 gallons, or 400 gallons times the number of bedrooms, whichever is greater.

For permanent structures other than dwellings, the capacity shall be based on measured flow rates or estimated flow rates. The tank capacity shall be at least five times the daily flow rate.

F. Holding tanks shall be located: in an area readily accessible to the pump truck under all weather conditions; as specified for septic tanks in table IV, part 7080.0170, subpart 2; where accidental spillage during pumping will not create a nuisance.

G. A contract for disposal and treatment of the sewage wastes shall be maintained by the owner with a pumper, municipality, agency, or firm established for that purpose.

H. Holding tanks shall be monitored to minimize the chance of accidental sewage overflows. Techniques such as visual observation, warning lights, or bells, or regularly scheduled pumping shall be used. For other establishments, a positive warning system shall be installed which allows 25 percent reserve capacity after actuation.

# MINNESOTA RULES 1993

1079

INDIVIDUAL SEWAGE TREATMENT SYSTEMS 7080.0210

Subp. 7, Figure 1.

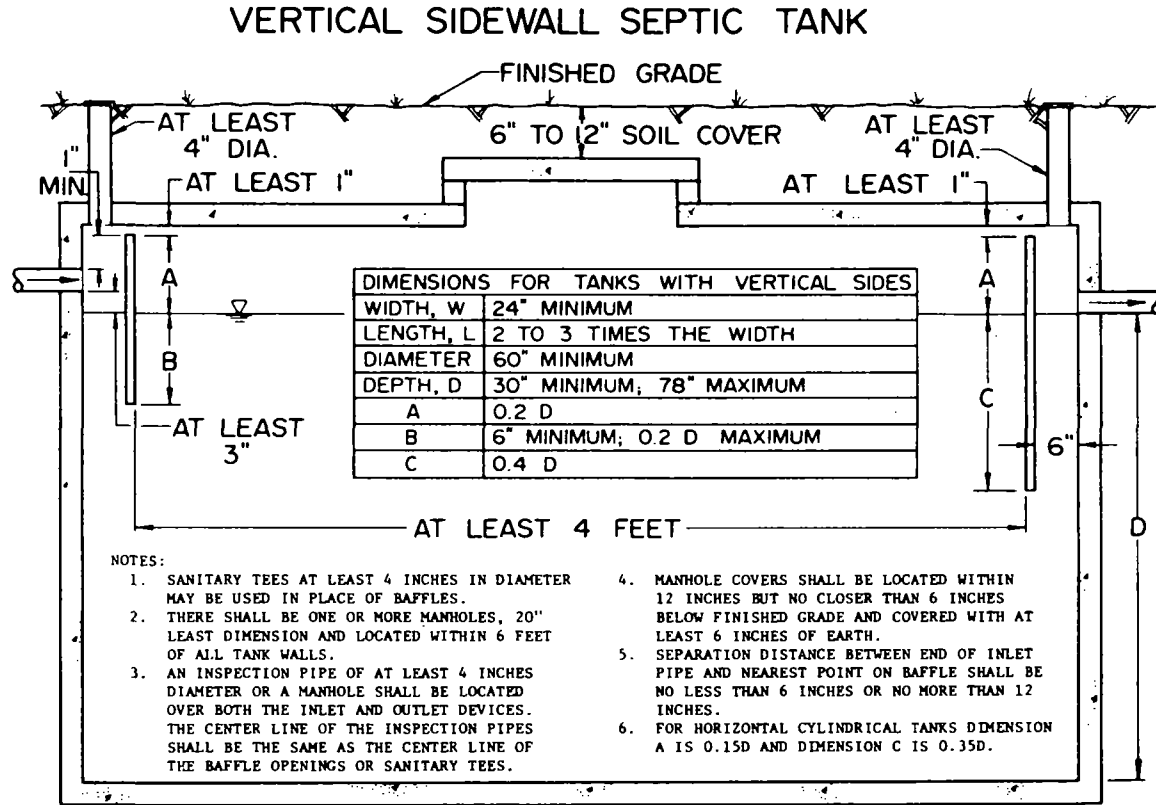

# MINNESOTA RULES 1993

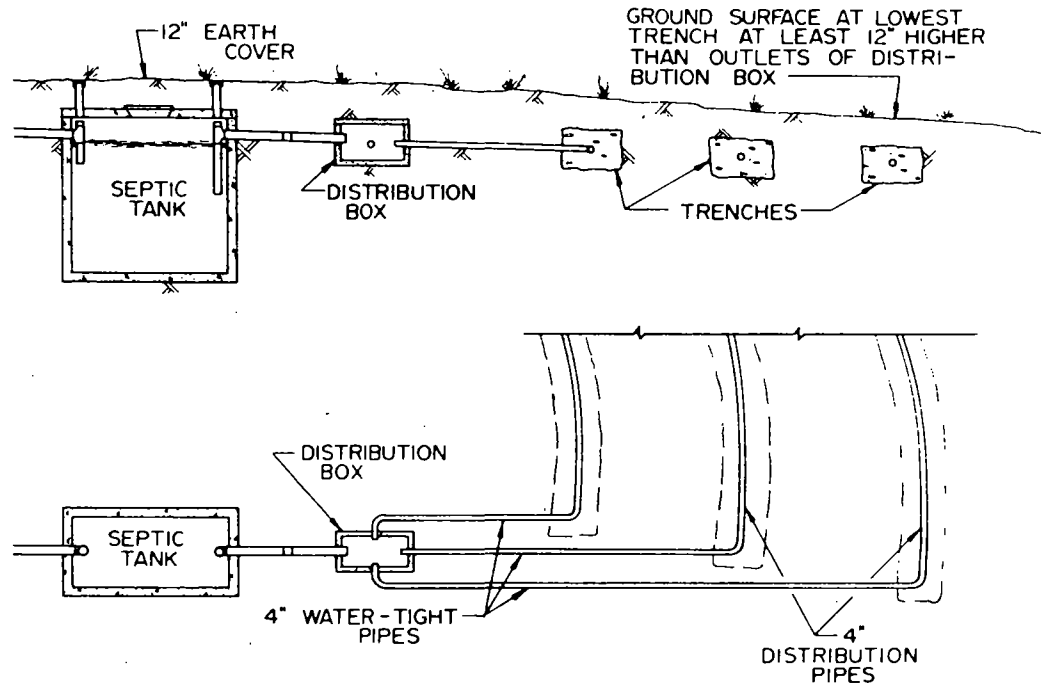

SEWAGE TREATMENT SYSTEM WITH DISTRIBUTION BOX

# MINNESOTA RULES 1993

Subp. 10. Figure 4.

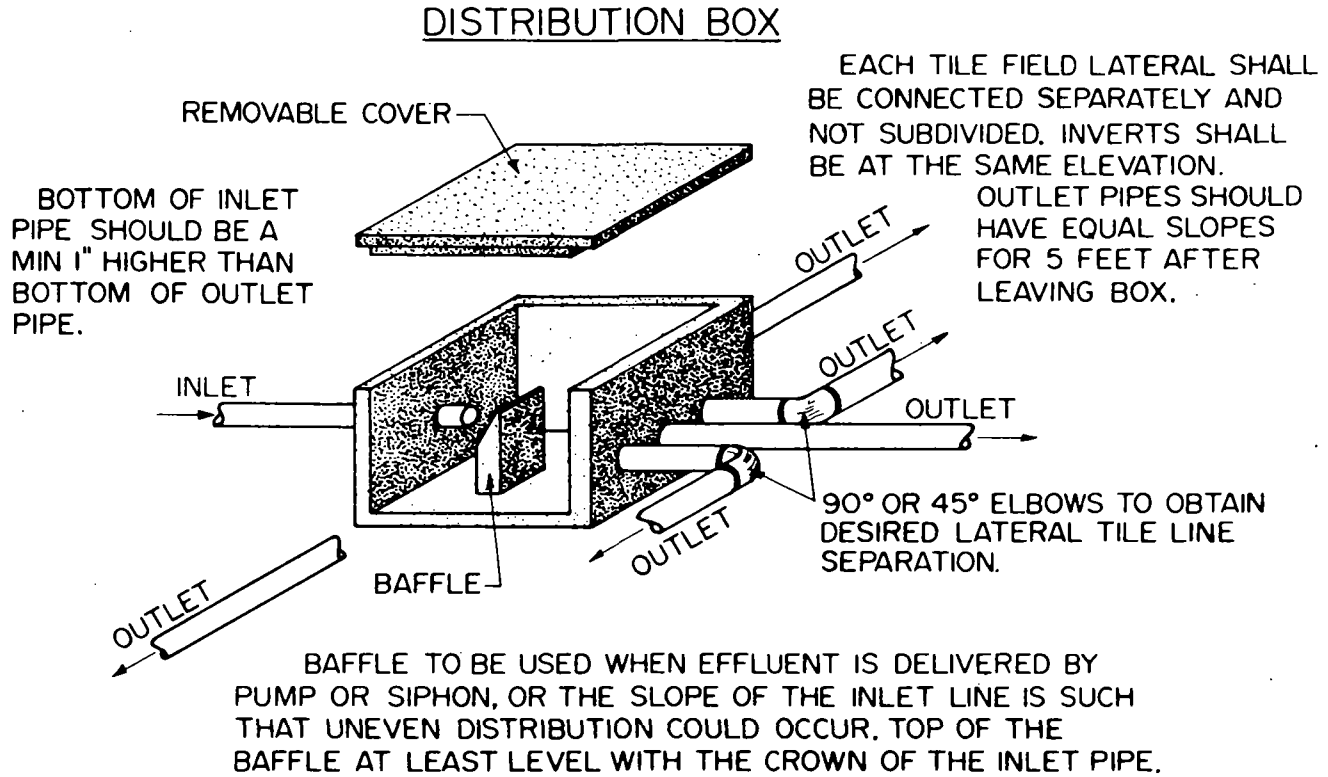

# MINNESOTA RULES 1993

Subp. 11. Figure 5.

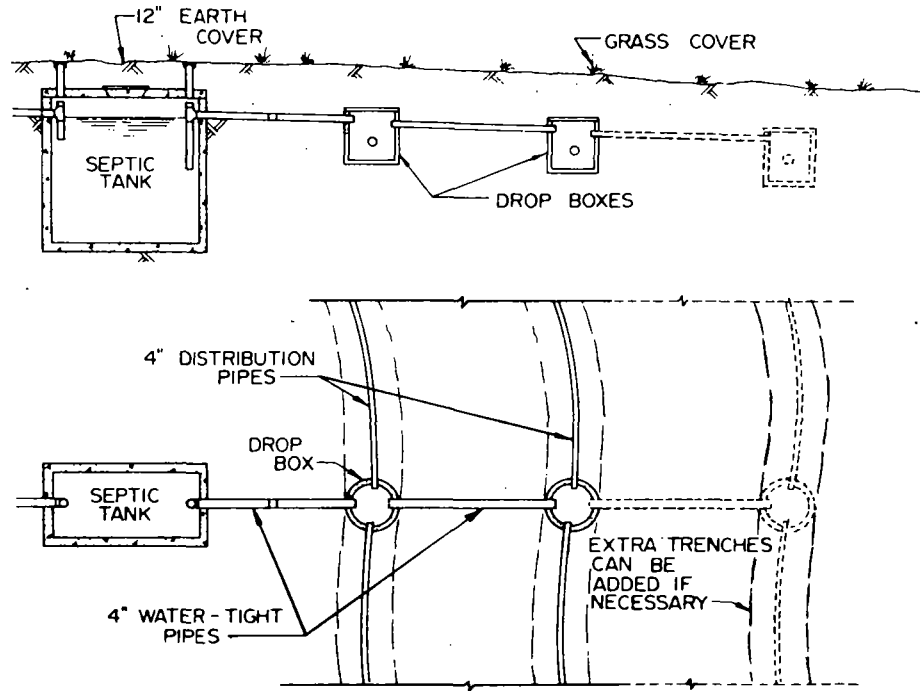

SEWAGE TREATMENT SYSTEM WITH DROP BOXES

# MINNESOTA RULES 1993

Subp. 12. Figure 6.

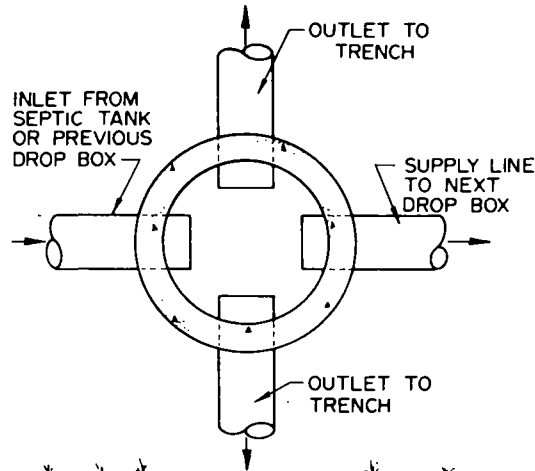

### NOTES

1. ALL PIPES SHOULD BE AT LEAST 4-INCH DIAMETER
2. ELEVATION OF INLET AND SUPPLY LINE TO NEXT DROP BOX MAY BE ADJUSTED UP OR DOWN FOR DESIRED EFFLUENT LEVEL IN TRENCH
3. SUGGESTED TRENCH LIQUID LEVEL IS 2" ABOVE TOP OF OUTLET PIPE
4. INVERT OF INLET MUST BE AT LEAST ONE INCH HIGHER THAN INVERT OF SUPPLY PIPE TO NEXT DROP BOX
5. TRENCHES MAY OUTLET ONE SIDE OR BOTH SIDES OF DROP BOX

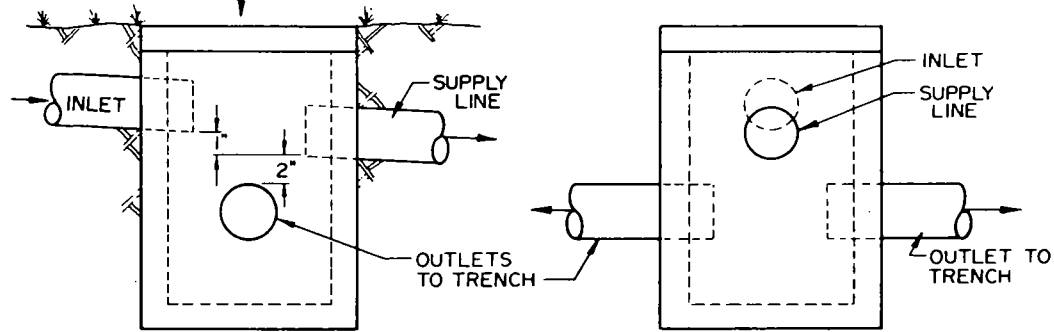

DROP BOX

### LAYOUT OF PERFORATED PIPE LATERALS FOR PRESSURE DISTRIBUTION

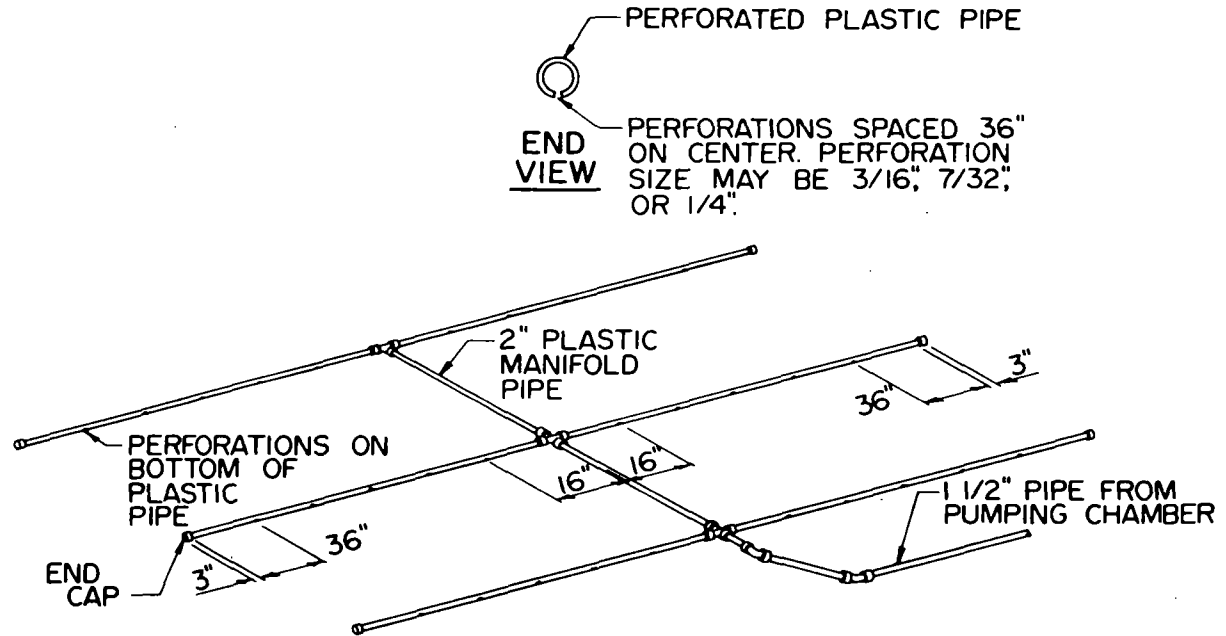



Subp. 14. Figure 8.

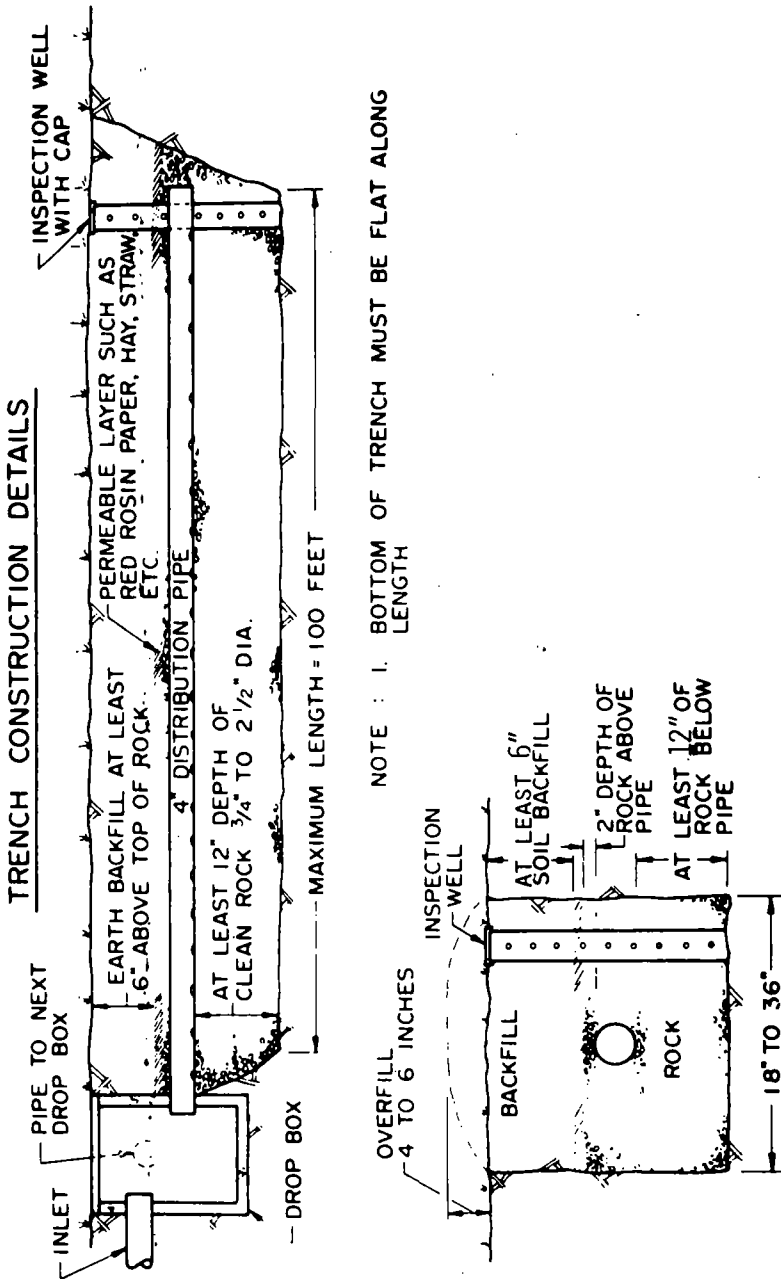

# MINNESOTA RULES 1993

Subp. 15, Figure 9.

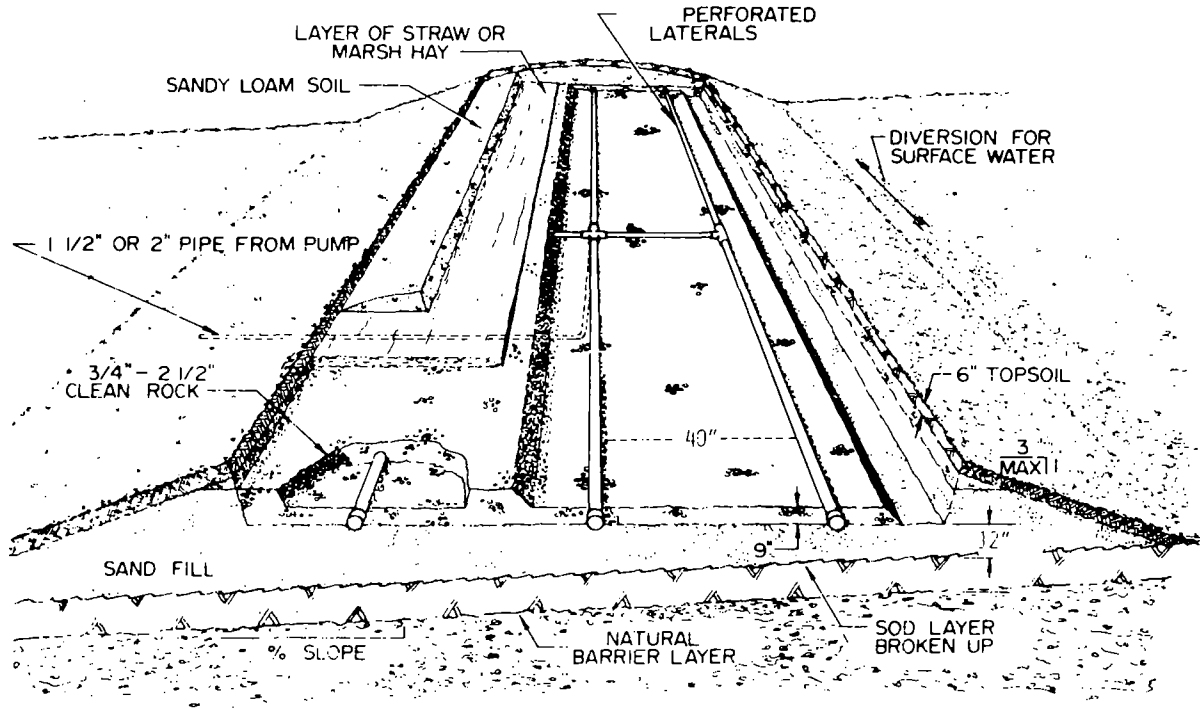

SEWAGE TREATMENT MOUND (PRESSURE DISTRIBUTION)

Statutory Authority: MS s 115.03 subd 1  
 History: 13 SR 2752  
 7080.0220 [Repealed, 13 SR 2752]  
 7080.0230 [Repealed, 13 SR 2752]  
 7080.0240 [Repealed, 13 SR 2752]