

CHAPTER 5230
DEPARTMENT OF LABOR AND INDUSTRY
PIPEFITTERS; POWER PIPING SYSTEMS

- 5230.0010 ORGANIZATION AND DUTIES OF ADVISORY COUNCIL FOR PIPEFITTING EXAMINATIONS.
- 5230.0020 DUTIES OF THE SECRETARY.
- 5230.0030 QUALIFICATIONS AND DUTIES OF INSPECTORS.
- 5230.0040 DEFINITIONS.
- 5230.0050 LICENSING AND REGISTRATION REQUIREMENT.
- 5230.0060 APPLICATIONS FOR REGISTRATION.
- 5230.0070 PIPEFITTER QUALIFICATIONS.
- 5230.0080 JOURNEYMAN PIPEFITTER QUALIFICATIONS.
- 5230.0090 EXAMINATION OF APPLICANTS FOR LICENSES.
- 5230.0100 FEES.
- 5230.0110 REGISTRATION OF TRAINEES.
- 5230.0120 RIGHTS OF LICENSED CONTRACTING PIPEFITTER.
- 5230.0130 DUTIES OF LICENSED CONTRACTING PIPEFITTERS.
- 5230.0140 DISPLAY OF LICENSES.
- 5230.0150 RIGHT TO DO BUSINESS.
- 5230.0160 SEVERANCE OF LICENSEE.
- 5230.0170 CHANGES AND TRANSFERS OF LICENSE.
- 5230.0180 SURRENDER OF LICENSE UPON REVOCATION.
- 5230.0190 DUPLICATE LICENSES.
- 5230.0200 AUTOMATIC REINSTATEMENT.
- 5230.0210 RENEWAL AFTER REVOCATION.
- CODE FOR POWER PIPING SYSTEMS**
- 5230.0250 PURPOSE.
- 5230.0260 SCOPE.
- 5230.0270 REFERENCES TO STANDARDS AND SPECIFICATIONS.
- 5230.0280 REQUIRED COMPLIANCE.
- 5230.0290 MINIMUM CONSTRUCTION STANDARD.
- 5230.0300 DIMENSION GUIDE.
- 5230.0310 PRESSURES AND TEMPERATURES.
- 5230.0320 MATERIALS.
- 5230.0330 TABLE 1 DEFINED.
- 5230.0340 FLANGES.
- 5230.0350 VALVES.
- 5230.0360 PRESSURE-REDUCING AND RELIEF VALVES.
- 5230.0370 FITTINGS.
- 5230.0380 SPECIAL FITTINGS.
- 5230.0390 BOLTING.
- 5230.0400 PIPE THREADS.
- 5230.0410 PIPE JOINTS.
- 5230.0420 SUBSTITUTE REQUIREMENTS.
- 5230.0430 GASKETS.
- 5230.0440 THERMAL EXPANSION.
- 5230.0450 HANGERS, SUPPORTS, AND ANCHORS.
- 5230.0460 PIPE SLEEVES.
- 5230.0470 DRAINS, DRIPS, AND STEAM TRAPS.
- 5230.0480 INSPECTION AND TESTS.
- 5230.0490 CLEANING.
- 5230.0500 HYDROSTATIC TESTS.
- 5230.0510 THICKNESS OF PIPE.
- 5230.0520 VARIATIONS IN PRESSURE AND TEMPERATURE.
- SPECIFIC REQUIREMENTS; STEAM PRESSURES ABOVE 350 PSI AND NOT ABOVE 2,500 PSI AND TEMPERATURES NOT IN EXCESS OF 1,100 DEGREES FAHRENHEIT**
- 5230.0550 VALVES.
- 5230.0560 FITTINGS.
- 5230.0570 PIPE JOINTS.
- 5230.0580 PIPE.
- 5230.0590 PIPES FOR SPECIAL USES.
- 5230.0600 OTHER PIPE PERMITTED.
- 5230.0610 BOLTING.
- STEAM PRESSURES ABOVE 125 PSI AND NOT ABOVE 250 PSI AND TEMPERATURES NOT IN EXCESS OF 450 DEGREES FAHRENHEIT**
- 5230.0650 VALVES.
- 5230.0660 FITTINGS.
- 5230.0670 PIPE JOINTS.
- 5230.0680 PIPE.
- 5230.0690 BOLTING.
- STEAM PRESSURES ABOVE 25 PSI BUT NOT ABOVE 125 PSI AND TEMPERATURES NOT IN EXCESS OF 450 DEGREES FAHRENHEIT**
- 5230.0750 VALVES.
- 5230.0760 FITTINGS.
- 5230.0770 PIPE JOINTS.
- 5230.0780 PIPE.
- 5230.0790 BOLTING.
- STEAM PRESSURES 25 PSI AND BELOW AND TEMPERATURES NOT IN EXCESS OF 450 DEGREES FAHRENHEIT**
- 5230.0850 VALVES.
- 5230.0860 FITTINGS.
- 5230.0870 PIPE JOINTS.
- 5230.0880 PIPE.
- 5230.0890 BOLTING.
- 5230.0950 BOILER FEED SYSTEMS AND OTHER WATER PIPING NOT OTHERWISE COVERED.
- 5230.0960 BOILER FEED PIPING.
- 5230.0970 BLOWOFF PIPING AND TANKS.
- 5230.0980 WATER COLUMN.
- 5230.0990 SAFETY VALVES.
- 5230.1000 STEAM PIPING.
- 5230.1010 SERVICE WATER AND CONDENSING WATER SYSTEMS.
- 5230.1020 INSTRUMENT AND CONTROL PIPING.
- 5230.1030 FABRICATION OF PIPE HANGERS, SUPPORTS, ANCHORS, SWAY BRACINGS, AND VIBRATION DAMPENERS.
- 5230.1040 SPACING BETWEEN PIPE SUPPORTS.
- 5230.1050 FABRICATION OF PIPE JOINTS OTHER THAN WELDED.
- 5230.1060 EXPANSION AND FLEXIBILITY.
- 5230.1070 WELDING OF PIPE JOINTS.
- 5230.1080 STANDARD QUALIFICATION FOR WELDING PROCEDURES, WELDERS, AND WELDING OPERATORS.
- 5230.1090 PROCEDURE QUALIFICATION.
- 5230.1100 PERFORMANCE QUALIFICATION.
- 5230.1110 RECOMMENDED FORMS OF PROCEDURE SPECIFICATION.
- 5230.1120 MATERIALS; THEIR SPECIFICATIONS AND IDENTIFICATION.
- 5230.1130 FITTINGS FOR INSTRUMENT AND CONTROL PIPING.
- 5230.1200 FIGURE 3: RECOMMENDED END PREPARATIONS.
- 5230.1210 FIGURE 4: BUTT WELDING OF PIPES OR FITTINGS OF UNEQUAL WALL THICKNESSES.
- 5230.1220 FIGURE 5: TYPICAL JOINTS WITH BACKING RING.
- 5230.1230 FIGURE 6: DETAILS OF WELDING FLANGES.
- 5230.1240 FIGURE 7: MINIMUM DIMENSIONS REQUIRED FOR SOCKET WELD FITTINGS.

5230.0010 PIPEFITTERS; POWER PIPING SYSTEMS

5120

5230.1250 FIGURE 8: POSITIONS OF
GROOVE WELDS.
5230.1260 FIGURE 9: QUALIFYING
POSITIONS.

5230.1270 ORDER OF REMOVAL OF TEST
SPECIMENS.

5230.0010 ORGANIZATION AND DUTIES OF ADVISORY COUNCIL FOR PIPEFITTING EXAMINATIONS.

Subpart 1. Election of chairman and secretary. The council shall organize by electing from its members a chairman and a secretary, which elections must be confirmed by the commissioner, Department of Labor and Industry before becoming effective.

Subp. 2. Biannual examinations. The council shall meet not less than two times a year for examinations and shall meet at such other times as it deems necessary or when called by the secretary.

Subp. 3. Examination and certification. The council shall examine all applicants for contracting or journeyman pipefitters' licenses, and after being satisfied of an applicant's qualifications and passage of the examination, shall certify the applicant to the department for issuance of a license.

Subp. 4. Violations by licensee. Upon information coming to the council of any licensee having obtained his license through error, misrepresentation, or fraud, or of his incompetency, or of a willful violation of any of the rules applicable to the work of pipefitting or to the adopted Code of Minimum Standards, the council shall make an investigation as to the probable truth of such information. If the facts elicited by such investigation appear to warrant a suspension or revocation of the licensee's license, the council shall file with the commissioner written charges against the licensee and recommendation for the suspension for a stated length of time or revocation of the license. Thereupon, the commissioner shall proceed in accordance with the provisions of Minnesota's Administrative Procedure Act. If the license is suspended, it shall be reinstated at the end of the period of suspension, and if it is revoked an application for a new license cannot be made within one year from the date of revocation.

Subp. 5. Reinstatement of suspended license. If any person whose license has been suspended or revoked has adjusted the cause for the suspension or revocation in a manner satisfactory to the council, or if the period of suspension has elapsed, the council shall so certify to the commissioner who may reinstate the suspended license or reissue the revoked license to such person, as the case may be, for the remainder of the license year.

Subp. 6. Recommendation for dismissal. The council shall notify the department of any misbehavior, neglect of duty, or incompetency, with a recommendation for dismissal if it deems the charge to be of sufficient gravity.

Subp. 7. Change in rules. The council shall recommend to the department any changes it deems advisable to these rules or the Code of Minimum Standards.

Subp. 8. Records. The council shall keep a record of all meetings, hearings, and examinations.

Subp. 9. Interpretation of code. The council shall determine questions of interpretation of provisions of the Code of Minimum Standards, which determinations shall be subject to review by the department, and shall submit questions of interpretation of the law or of these rules directly to the department.

Subp. 10. Performance of duties. The council shall faithfully perform duties outlined by the Code of Minimum Standards and these rules.

Subp. 11. Member approval. A member of the council may be removed during his term of office in accordance with Minnesota Statutes, section 15.059, subdivision 4.

Statutory Authority: *MS s 175.171; 326.48*

History: *14 SR 1877*

MINNESOTA RULES 1991

5121

PIPEFITTERS; POWER PIPING SYSTEMS 5230.0030

5230.0020 DUTIES OF THE SECRETARY.

The secretary of the council shall be an employee of the department and have general charge of the office of the Pipefitting Division and its books and records, including those of the council. Specifically, his duties shall include the following:

A. to maintain a record of all proceedings of the council, together with the necessary registers pertaining to applications for examinations and licenses, showing thereon, for each, the date of application, name, qualifications, place of business, place of residence, and whether the license was granted or not;

B. to receive all moneys derived for examination fees and remit same to department;

C. to call meeting of the council whenever he deems the same to be necessary, or when requested by a majority of the council or by the commissioner;

D. to issue notices and summons to licensees, complaints and witnesses of hearings by the council on charges or violations of the law or the Code of Minimum Standards;

E. to issue notices to applicants for licenses of the time and place of examination;

F. to keep complete and detailed records of complaints and evidence pertaining thereto and have the same at hearings of the council thereon;

G. to furnish to the council such information in his possession as may be necessary for the proper performance of its duties or as it may from time to time require;

H. to prepare, with the advice and assistance of the council, a budget of expenses quarterly and transmit a copy thereof to the department;

I. to supervise the duties of inspectors and employees of the division and notify the council of any incompetence, misbehavior, or neglect of duty by them; and

J. to issue all licenses upon receipt of certification from the council, and approved by the commissioner, that the applicant has qualified and has successfully passed the examination. He shall sign and issue renewals of licenses without such certification.

Statutory Authority: *MS s 175.171; 326.48*

History: *14 SR 1877*

5230.0030 QUALIFICATIONS AND DUTIES OF INSPECTORS.

Inspectors shall be responsible for the fulfillment of their duties, which shall include the following:

A. They shall report to the secretary of the council or the department all violations of the law or Code of Minimum Standards, with recommendation for action on such violations.

B. They shall inspect the installation of all high pressure piping and appurtenances when requested or when deemed advisable to determine if such installation meets code requirements. They shall also inspect high pressure piping underground and overhead or in any building at any time to determine the safety operations of such piping and appurtenances.

C. They shall at all times be alert in ascertaining whether persons engaging in the business or occupation of high pressure piping are complying with the provisions of the registration act and Code of Minimum Standards, and especially as to whether or not such persons are licensed.

D. They shall be thoroughly conversant with all provisions of the registration act, the Code of Minimum Standards, and these rules.

E. They shall at all times be courteous in the conduct of their duties and shall acquaint the persons engaged in the business of high pressure piping with the provisions of the registration act and Code of Minimum Standards.

5230.0030 PIPEFITTERS; POWER PIPING SYSTEMS

5122

F. They shall be furnished with a badge or certificate of identification and shall display the same whenever requested when on duty.

G. They shall refrain from debating any question of disputes where violations are found, but shall be empowered to inform violators of the provisions of the code.

H. They shall not divulge any of their opinions or findings pertaining to their duties as inspectors to any person not connected with the Division of Pipefitting Standards unless instructed to do so by their superior officers, nor shall they divulge to the public any matters of a private nature in the possession of the division.

I. They shall not have authority to start any action or legal proceeding pertaining to the enforcement of the registration act or Code of Minimum Standards unless instructed by their superior officers to do so.

J. They shall have authority to give notice to installers or the property owner by attaching a tag to the piping or equipment advising that the piping installation does not meet the Minnesota code requirements or that it was installed by persons not licensed to make such installation and that the equipment shall not be put into operation until the law and code are complied with and the tag removed by an authorized person.

Statutory Authority: *MS s 175.171; 326.48*

History: *14 SR 1877*

5230.0040 DEFINITIONS.

Subpart 1. Contracting pipefitter. A "contracting pipefitter" is any person engaged in the planning, superintending, and practical installation of high pressure piping and appurtenances, and otherwise lawfully qualified to construct high pressure piping installations and make replacements to existing plants, who is also qualified to conduct the business of high pressure piping installations and who is familiar with the laws, rules, and minimum standards governing same.

Subp. 2. High pressure steam. "High pressure steam" shall mean a pressure in excess of 15 pounds per square inch.

Subp. 3. Journeyman pipefitter. A "journeyman pipefitter" is any person other than a contracting pipefitter who as his principal occupation is engaged in the practical installation of high pressure piping and appurtenances in the employ of a contracting pipefitter.

Subp. 4. Pipefitter trainee. A "pipefitter trainee" is any person other than a contracting or journeyman pipefitter, whose principal occupation is learning and assisting in the installation of high pressure piping and appurtenances under the direct supervision of a licensed pipefitter.

Statutory Authority: *MS s 175.171; 326.48*

History: *14 SR 1877*

5230.0050 LICENSING AND REGISTRATION REQUIREMENT.

No person, firm, corporation, or association shall engage in the business or work at the occupation of high pressure piping in the state of Minnesota without first obtaining a license and being registered as a contracting or journeyman pipefitter, as the case may be, and no licensed contractor shall employ a journeyman pipefitter, to install high pressure piping unless such journeyman is a licensed pipefitter; and no person shall work as a pipefitter trainee for more than 30 days without being registered as such, nor longer than four years without making application for examination and license as a pipefitter.

Licenses shall be granted as contracting or journeyman pipefitters upon proof of qualifications therefor as hereinafter provided, and no pipefitter trainee shall be registered as such who is not at least 16 years of age.

An applicant for a contractor's license to do business in the name of a firm or partnership shall be a bona fide member or employee of such firm or partnership. An applicant for a contractor's license to do business in the name of a corporation shall be a regular employee or member in such corporation.

Statutory Authority: *MS s 175.171; 326.48*

History: *14 SR 1877*

5230.0060 APPLICATIONS FOR REGISTRATION.

Subpart 1. Contractor and journeymen licenses. Application for a contractor's license and registration shall be made to the secretary of the Division of Pipefitting Standards at least 30 days prior to the next scheduled examination on blanks provided for that purpose by the division. Application for a journeyman's license shall be filed with the division at least ten days prior to the next examination. The council may waive the rule applying to journeyman examinations in emergency cases. If the statements made by the applicant in said application form indicate that he possesses the necessary qualifications to take an examination, the secretary shall notify him of the time and place of examination. If, on examination, the applicant fully qualifies, the council shall so certify to the department, which shall thereupon issue to him a license as a contracting or journeyman pipefitter, as the case may be, for the remainder of the calendar year. If an applicant fails to qualify at an examination, the council shall so certify to the secretary, who shall notify the applicant of his failure to pass.

Subp. 2. Reexamination. Any applicant who fails to pass the first examination may be reexamined at the next regular examination of which he is notified without the payment of another fee, but thereafter, all applications for reexamination shall be accompanied by the regular statutory fee.

Statutory Authority: *MS s 175.171; 326.48*

History: *14 SR 1877*

5230.0070 PIPEFITTER QUALIFICATIONS.

Applicants for license as a contracting pipefitter shall:

- A. be at least 21 years of age;
- B. possess sufficient education to read and comprehend blueprints, specifications, and terms of contracts, and to compute the cost of installing high pressure piping and equipment;
- C. have worked at the trade of pipefitting for at least five years;
- D. be examined as to their knowledge of high pressure pipefitting, the requirements of the laws and minimum standards for the installation of high pressure piping in the state of Minnesota, their ability to lay out a plan of high pressure piping, and their knowledge of the physics and mechanics applicable to high pressure piping;
- E. generally demonstrate to the council their fitness to properly, intelligently, and lawfully carry on the business of a contracting and employing pipefitter in the state of Minnesota;
- F. be of good moral character;
- G. pay an examination fee; and
- H. pass the required examination by at least 70 percent.

Statutory Authority: *MS s 175.171; 326.48*

History: *14 SR 1877*

5230.0080 JOURNEYMAN PIPEFITTER QUALIFICATIONS.

Applicants for license shall:

- A. be at least 20 years of age;

5230.0080 PIPEFITTERS; POWER PIPING SYSTEMS

5124

- B. possess sufficient education to read and comprehend blueprints and specifications for the installation of high pressure piping;
- C. be of good moral character;
- D. have been a registered pipefitter trainee or journeyman pipefitter for at least four years;
- E. pay an examination fee; and
- F. pass the required examination by at least 70 percent.

Statutory Authority: *MS s 175.171; 326.48*

History: *14 SR 1877*

5230.0090 EXAMINATION OF APPLICANTS FOR LICENSES.

Subpart 1. Contents. Examinations shall consist of written or oral questions and drawings of plans and sketches, except that when an applicant is handicapped for a written examination, his examination may be entirely oral. All questions and sketches shall pertain to practical experience and knowledge of pipefitting and be standard, but may be changed from time to time.

Subp. 2. Grading. Examination papers shall be reviewed by at least two members of the council. Each answer or sketch shall be graded on the basis of 100 for perfect. The council may grant up to ten percent for experience in the trade or to persons who are certified welders based upon actual experience on high pressure pipefitting as shown on the application. An average of at least 70 percent shall constitute the passing mark.

Subp. 3. Test results. Applicants shall be notified of the outcome of their examination after their papers have been graded. The notice to those who failed to pass shall inform them of their privilege of reexamination without the payment of another fee at the next examination held of which they are notified.

Statutory Authority: *MS s 175.171; 326.48*

History: *14 SR 1877*

5230.0100 FEES.

Subpart 1. General. Fees shall be for the examination and to cover the cost of a license for the remainder of the calendar year in which the examination is taken or for which the application is made if the applicant qualifies for a license.

Subp. 2. Application for renewal. A license that has expired within one year of application for renewal may be renewed without an examination on filing an application for renewal with the Department of Labor and Industry, accompanied by the fee required in this part. An application for renewal received by the department more than 30 days after the expiration date of the license must be accompanied by the late fee in subpart 3, item F.

If a license holder has failed to submit an application for renewal within one year of the date of the expiration of the license, renewal is not allowed unless the applicant files the application, pays the fee required by this part, and passes the examination required by this chapter.

Subp. 3. Examination and license. The fees for examination and license are as follows:

- A. pipefitter journeyman, examination and license, \$50;
- B. renewal of pipefitter journeyman license, \$30;
- C. contracting pipefitter, examination and license, \$125;
- D. renewal of contracting pipefitter license, \$110;
- E. pipefitter contractor bond and insurance processing, \$50; and
- F. late fees:
 - (1) contractor, \$125; and
 - (2) journeyman, \$50.

MINNESOTA RULES 1991

5125

PIPEFITTERS; POWER PIPING SYSTEMS 5230.0120

Payment of examination and license fees must accompany the application. There will be no refund of fees paid.

Subp. 4. Permit to construct or install power piping systems. A person, firm, or corporation that constructs or installs power piping systems must file an application for a permit with the Department of Labor and Industry, or with a municipality that is authorized by law to issue that type of permit, before beginning construction or installation. The department's fees for a permit to construct or install power piping systems are:

A. filing fee (application for permit), \$25; and

B. inspection fee, 0.010 of the first \$1,000,000, plus 0.0075 of the next \$2,000,000, plus 0.0005 of the next \$47,000,000, plus 0.00025 of the amount over \$50,000,000 of the cost of constructing or installing the power piping systems as defined under part 5230.0260.

Statutory Authority: *MS s 16A.128; 183.44; 183.545; 326.46 to 326.50*

History: *9 SR 2008; 12 SR 1148*

5230.0110 REGISTRATION OF TRAINEES.

Subpart 1. [Repealed, 14 SR 1877]

Subp. 2. [Repealed, 14 SR 1877]

Subp. 2a. Annual registration, supervision. All contracting pipefitters shall, within ten days of the employment of a pipefitter trainee, inform the department of the employment of the pipefitter trainee, giving the name, address, age, and date of employment of the pipefitter trainee.

All persons learning the trade of pipefitting shall register with the department on an annual basis until the four years of training are documented. The registration shall be made at the time of initial registration with the department and annually after that on the anniversary of the initial registration. Upon completion and verification of four years of employment and training by a licensed contracting pipefitter, the pipefitter trainee shall make application for examination and license as a journeyman.

All persons learning the trade of pipefitting shall be under the direct supervision of a contracting or journeyman pipefitter. The minimum ratio of pipefitter trainees to licensed pipefitters on the jobsite shall be:

A. one pipefitter trainee for the first licensed pipefitter; and

B. one pipefitter trainee for every three licensed pipefitters after that; provided, that at least one journeyman or contracting pipefitter must be on the jobsite at all times when work is in progress.

Subp. 3. Changes in employment or address. All registered pipefitter trainees shall inform the department of changes of employment and their address.

Statutory Authority: *MS s 175.171; 326.48*

History: *14 SR 1877*

NOTE: This part applies to all high pressure piping projects after January 31, 1990, to high pressure pipefitter trainees registered after January 31, 1990, and to all high pressure pipefitter apprentices registered with the department before February 1, 1990.

NOTE: On January 31, 1990, a temporary restraining order was issued restraining the enforcement of the rules adopted at 14 SR 1877. See: Boise Cascade Corporation vs Kenneth Peterson, Commissioner of the Department of Labor and Industry, State of Minnesota, case file CZ4-90-48 (Federal District Court, District of Minnesota).

5230.0120 RIGHTS OF LICENSED CONTRACTING PIPEFITTER.

A contracting pipefitter's license shall entitle him to work as a journeyman pipefitter under rules applicable to journeyman pipefitters, but a journeyman pipefitter's license shall not entitle the holder thereof to do business as a contracting pipefitter.

Statutory Authority: *MS s 175.171; 326.48*

History: *14 SR 1877*

5230.0130 DUTIES OF LICENSED CONTRACTING PIPEFITTERS.

A contracting pipefitter employing a journeyman pipefitter or a pipefitter trainee shall comply with all the laws, rules, and minimum standards of the state of Minnesota, paying promptly for labor and material furnished an owner, and reporting income tax and conforming to the laws governing the relationship of master and servant, including the carrying or workmen's compensation insurance, paying the Social Security tax, paying wages when due, furnishing written contracts of employment, and employing licensed pipefitters on high pressure pipe work.

Statutory Authority: *MS s 175.171; 326.48*

History: *14 SR 1877*

5230.0140 DISPLAY OF LICENSES.

All certificates of licenses of a contracting pipefitter shall be posted in a conspicuous place in the office of the contractor's place of business and license cards issued to persons shall at all times be in possession of the licensee during business hours and shall be displayed when required by a representative of the Division of Pipefitting Standards or the department. Such card shall at no time be in the possession of any other person than the licensee to whom it was issued. Licenses issued hereunder shall not be transferable.

Statutory Authority: *MS s 175.171; 326.48*

History: *14 SR 1877*

5230.0150 RIGHT TO DO BUSINESS.

The right of any firm, corporation, or association to do business under a license issued to a member thereof shall depend upon the holder's active continuance in the business of such firm, corporation, or association.

Statutory Authority: *MS s 175.171; 326.48*

5230.0160 SEVERANCE OF LICENSEE.

If the member of a firm, corporation, or association holding a license for it shall sever his connection with such concern, the concern shall have no right to continue the business of high pressure pipefitting without procuring another license.

Statutory Authority: *MS s 175.171; 326.48*

History: *14 SR 1877*

5230.0170 CHANGES AND TRANSFERS OF LICENSE.

Changes in the name or place of business of a firm, corporation, or association for which an individual is holding a license and the removal of the residence of a licensed journeyman from one city to another shall be reported immediately to the secretary of the Division of Pipefitting Standards by the licensee.

Statutory Authority: *MS s 175.171; 326.48*

History: *14 SR 1877*

5230.0180 SURRENDER OF LICENSE UPON REVOCATION.

When a pipefitter's license is revoked, the licensee shall at once surrender his certificate and identification card to the secretary of the Division of Pipefitting Standards.

Statutory Authority: *MS s 175.171; 326.48*

History: *14 SR 1877*

5230.0190 DUPLICATE LICENSES.

Duplicate licenses and identification cards may be issued by the secretary upon proof that the original is lost or mutilated.

Statutory Authority: *MS s 175.171; 326.48*

MINNESOTA RULES 1991

5127

PIPEFITTERS; POWER PIPING SYSTEMS 5230.0280

5230.0200 AUTOMATIC REINSTATEMENT.

When a license has for any cause been suspended for a stated time, it shall automatically be again in force on the expiration of the period of suspension if such period is within the time for which the license was issued; provided, that if the cause for suspension has been adjusted in a manner satisfactory to the council, it may recommend to the department a reduction of the period of suspension or immediate reinstatement of the license.

Statutory Authority: *MS s 175.171; 326.48*

5230.0210 RENEWAL AFTER REVOCATION.

When a license has for any cause been revoked, it cannot be renewed without the procedure for an original license; provided, that where a license has been revoked for some cause other than incompetency the department may in its discretion waive the requirement of an examination if an application for a new license is made within one year from the date of revocation, but not thereafter.

Statutory Authority: *MS s 175.171; 326.48*

CODE FOR POWER PIPING SYSTEMS

5230.0250 PURPOSE.

This code prescribes minimum requirements for design, manufacture, test, and installation of power piping systems, as defined below, for steam generating plants, central heating plants, industrial plants, and district heating.

Statutory Authority: *MS s 326.46*

5230.0260 SCOPE.

"Power piping systems" shall be understood to include all steam piping and the component parts such as pipe, flanges, bolting, gaskets, valves, and fittings, within or forming a part of the above-mentioned plants, including central and district heating steam or hot water distribution piping away from the plant, building heating piping when the pressure exceeds 15 psi gage for steam, or 30 psi gage for hot water and a temperature exceeding 250 degrees Fahrenheit, whether the piping is installed underground or elsewhere.

Valves, fittings, and piping for boilers, as prescribed in the ASME Code for Power Boilers, are within the scope for this code but provisions of the ASME Code for Power Boilers shall govern where they exceed corresponding requirements of this code.

Economizers, heaters, tanks, and other pressure vessels are outside the scope of this code, but connecting piping shall conform to the requirements herein specified.

Statutory Authority: *MS s 326.46*

5230.0270 REFERENCES TO STANDARDS AND SPECIFICATIONS.

Unless otherwise specified, reference to an "American Standard," in this code is to the latest revision of that standard as approved by the American Standards Association. The use of the latest revisions of all other standards or specifications mentioned in this code is intended.

The policy of the sectional committee in making reference to standards and specifications is stated in part 5230.1120, subpart 4.

Statutory Authority: *MS s 326.46*

5230.0280 REQUIRED COMPLIANCE.

The standards and specifications cited herein are minimum requirements. Dimensions and materials, unless otherwise specified, shall comply with these standards and specifications.

Statutory Authority: *MS s 326.46*

5230.0290 PIPEFITTERS; POWER PIPING SYSTEMS

5128

5230.0290 MINIMUM CONSTRUCTION STANDARD.

Construction shall be equal to or better than required by this code. Materials shall have physical and chemical properties at least equal to its minimum requirements.

Statutory Authority: *MS s 326.46*

5230.0300 DIMENSION GUIDE.

Adherence to American Standard dimensions is strongly recommended wherever practicable. However, other designs of at least equal strength and tightness and capable of withstanding the same hydrostatic test requirements may be used.

Statutory Authority: *MS s 326.46*

5230.0310 PRESSURES AND TEMPERATURES.

All pressures referred to in this code, unless otherwise stated, are expressed in pounds per square inch above atmospheric pressure, i.e., psi gage. All temperatures, unless otherwise stated, are the metal temperatures of the respective materials.

Statutory Authority: *MS s 326.46*

5230.0320 MATERIALS.

Subpart 1. Minimum requirement. The materials used shall be capable of meeting the physical and chemical requirements and tests of the respective specifications in Table 1 of ASA B31.1-1955 Code for Pressure Piping. Any materials allowed under this code shall not be used for service in excess of pressures and temperatures herein specified except as noted.

Subp. 2. Future materials. Should it be desired to use any materials or methods of manufacture not now covered by this code or which may be developed in the future, it is intended that the manufacturer shall provide details of design and construction which will be as safe as otherwise provided by the rules in the code. Where it is desired to use materials not included in Table 1, written application shall be made to the department fully describing the proposed material and the contemplated use, requesting that an allowable stress (S value) be assigned. Such materials shall not be used until the stress values have been approved.

Statutory Authority: *MS s 326.46*

5230.0330 TABLE 1 DEFINED.

"Table 1" refers to American Standard Code for Pressure Piping and is not printed in this code book.

Statutory Authority: *MS s 326.46*

5230.0340 FLANGES.

The dimensions and drilling for all line or end flanges shall conform to the requirements of the B16 series of the American Standards for cast iron, steel, and bronze material for the respective pressures and temperatures as stated in the specific requirements of parts 5230.0570, 5230.0660, 5230.0670, and 5230.0770. For marking of flanges, see this code.

Statutory Authority: *MS s 326.46*

5230.0350 VALVES.

It is mandatory that valves be:

A. of the design or equal to the design which the manufacturer thereof recommends for the service; and

B. of materials allowed by the code for the pressure and temperature.

Body metal thickness of steel valves shall not be less than that required by

American Standard for Steel Pipe Flanges and Flanged Fittings, ASA B16.5. Each valve, of a size permitting, shall bear the maker's name or trademark and reference symbol to indicate the service conditions for which the maker guarantees it. See also part 5230.1120, subpart 2.

All screw-end valves shall be threaded according to the American Standard for Taper Pipe Threads (B2.1). Flanged-end valves shall have connecting-end flanges conforming to the B16 series of American Standards for cast iron, steel, and bronze corresponding to the maximum pressure and service for which the valve is to be used. Face-to-face dimensions shall comply with B16.10 for types of valves covered in the standard. Welding-end valves may be used if welded directly into the line in accordance with part 5230.1070. It is recommended that the ends be prepared in accordance with details shown therein.

Statutory Authority: *MS s 326.46*

5230.0360 PRESSURE-REDUCING AND RELIEF VALVES.

Subpart 1. Location of valves. Where pressure-reducing valves are used, one or more relief or safety valves shall be provided on the low-pressure side of the reducing valve in case the piping or equipment on the low-pressure side does not meet the requirements for the full initial pressure. The relief or safety valve shall be located adjoining or as close as possible to the reducing valve. Proper protection shall be provided to prevent injury or damage caused by escaping fluid or steam and in compliance with part 5230.0970, subpart 3, item C.

Subp. 2. Hand-controlled bypasses. The use of hand-controlled bypasses around a reducing valve is permissible provided the bypass does not have a greater capacity than the reducing valve and the low-pressure side is adequately protected by relief valves.

Subp. 3. Dimensions and materials. The flange dimensions, wall thickness, and material of reducing and relief valves shall conform to the requirements specified herein for valves and fittings for the pressures and temperatures to which they may be subjected.

Subp. 4. Pressure gage installation. It is mandatory that a pressure gage be installed on the low-pressure side of a reducing valve. Where two or more reducing valves are installed in series, a pressure gage shall be installed on the low-pressure side of each pressure-reducing valve.

Subp. 5. Exhaust and pump suction lines. Exhaust and pump suction lines for any service and pressure shall have relief valves of suitable size unless the lines and attached equipment are designed for the maximum pressure to which they may accidentally or otherwise be subjected, or unless a suitable alarm indicator, such as a free-blowing relief valve is installed where it will warn the operator of such equipment.

Statutory Authority: *MS s 326.46*

5230.0370 FITTINGS.

The minimum metal thickness of all flanged or screwed fittings and the strength of factory-made welding fittings shall not be less than that specified for the pressures and temperatures in the respective American Standards. For markings on fittings, see part 5230.1120, subpart 2.

Statutory Authority: *MS s 326.46*

5230.0380 SPECIAL FITTINGS.

Where special screwed or flanged fittings are required to overall dimensions differing from those of the regular shapes specified in the American Standards referred to, they shall conform to these standards with respect to minimum wall thickness and flange dimensions, if flanged, and to the specific requirements of this section of the code. They shall be designed to withstand the hydrostatic test pressures as specified in part 5230.0500. All material shall conform to the requirements given herein for the particular pressure and temperature rating.

Special welded steel fittings such as elbows, tees, etc., may be used if they comply with the requirements of section 6 of this code. Fittings with welding ends may be used in accordance with the specific requirements of this part, parts 5230.0560, subpart 3; 5230.0600, subpart 2; 5230.0760, subpart 2; or 5230.0860, subpart 2 regarding the service intended.

Statutory Authority: *MS s 326.46*

5230.0390 BOLTING.

Subpart 1. Standards. The following standards shall apply to bolting:

A. For steam service pressure in excess of 250 psi or for steam or water service temperature exceeding 450 degrees Fahrenheit, the bolting material shall conform to ASTM Specification A 193.

B. For temperatures exceeding 750 degrees Fahrenheit only bolt-studs are recommended.

C. When cast iron flanges are used, bolting material shall be of carbon steel conforming to ASTM Specification A 307, Grade B, or A 107, Grade 1120, except as otherwise permitted in part 5230.1050, subpart 4.

Subp. 2. Flange bolts or bolt-studs. Flange bolts or bolt-studs shall be of the dimensions and material specified for the purpose in the corresponding American flange standards. Bolts or bolt-studs shall extend completely through the nuts and, if desired, may have reduced shanks of a diameter not less than the diameter at root of threads.

Subp. 3. Carbon steel bolts. Carbon steel bolts may be American Standard regular square or heavy hexagon bolts and shall have American Standard heavy semifinished hexagonal nuts (B18.2).

Subp. 4. Alloy steel bolt-studs. Alloy steel bolt-studs may be threaded at both ends or full length, or American Standard (B18.2) heavy semifinished hexagon bolts may be used. They shall have American Standard heavy semifinished hexagonal nuts (B18.2). It is recommended that all bolts or bolt-studs and accompanying nuts intended for high-temperature service be threaded in accordance with American Standard B1.1, Class 2A external threads, Class 2B internal threads.

Subp. 5. Nuts. Nuts shall be American Standard heavy semifinished hexagonal (B18.2) and shall be threaded as indicated herein. Nuts shall conform to ASTM Specification A194. Nuts cut from bar stock so that their axes will be parallel to the direction of rolling of the bar may be used in all sizes for joints in which one or both flanges are cast iron; they shall not be used for joints in which both flanges are steel except for nut sizes one-half inch and smaller, which are permissible in any case.

Subp. 6. Washers. Washers, when used under nuts, shall be of forged or rolled steel.

Statutory Authority: *MS s 326.46*

5230.0400 PIPE THREADS.

All pipe threads on pipes, valves, fittings, etc., shall conform to the American Standard for Taper Pipe Threads B2.1.

Statutory Authority: *MS s 326.46*

5230.0410 PIPE JOINTS.

Pipe joints shall comply with fabrication rules and details in part 5230.1050, subpart 4.

Statutory Authority: *MS s 326.46*

5230.0420 SUBSTITUTE REQUIREMENTS.

Qualification of welding procedures and welders under Section IX of the ASME Boiler and Pressure Vessel Code is acceptable in lieu of the requirements of part 5230.1070.

Statutory Authority: *MS s 326.46*

MINNESOTA RULES 1991

5131

PIPEFITTERS; POWER PIPING SYSTEMS 5230.0460

5230.0430 GASKETS.

Gaskets, where required, shall be of a material that resists attack by the fluid carried in the pipe line, shall be strong enough to hold the pressure, and perform the purpose intended throughout the temperature range encountered. Gaskets shall be as thin as the finish of surfaces will permit to reduce possibility of blowing out.

For all lines under pressure and above 250 degrees Fahrenheit the gaskets shall be metallic, asbestos, or other nonburning material. For further details concerning gaskets, refer to part 5230.1050, subpart 5.

Statutory Authority: *MS s 326.46*

5230.0440 THERMAL EXPANSION.

Thermal expansion of piping shall be provided for preferably by pipe bends, offsets, or changes in direction of the pipe line itself. Where pipe bends or offsets are used or where the pipe line direction is changed to provide for expansion, the provisions of part 5230.1060, subpart 5 shall be followed.

Expansion joints of either the slip-sleeve or swivel types may be used if: their materials conform to this code, their structural and working parts are of ample proportions, and for pressures above 15 psi, the design prevents complete disengagement of the working parts while in service.

Nonreinforced corrugated copper expansion joints shall not be used for steam pressures exceeding 25 psi. Corrugated copper expansion joints when reinforced with exterior rings or sleeves may be used for steam pressures not exceeding 200 psi.

Nothing in this part shall be construed to limit using expansion joints, corrugated pipe, or creased, corrugated, wrinkled, or plain bends made of the same material as the remainder of the pipe, or of other material suitable for the pressure and temperature conditions.

Statutory Authority: *MS s 326.46*

5230.0450 HANGERS, SUPPORTS, AND ANCHORS.

Piping and equipment shall be supported in a thoroughly substantial and workmanlike manner, rigid enough to prevent excessive vibration, and anchored sufficiently to prevent undue strains on boilers and equipment served. Hangers, supports, and anchors shall be made of durable materials. In tunnels and buildings of permanent fireproof construction, these materials shall be noncombustible. In buildings of nonfireproof construction, piping may be supported on or hung from wood structures if all piping used for conveying fluid at temperatures above 250 degrees Fahrenheit is spaced or insulated from such wooden members to prevent dangerous heating.

Hangers and supports shall permit free expansion and contraction of the piping between anchors. All piping shall be carried on adjustable hangers or properly leveled supports, and suitable springs, sway bracing, vibration dampeners, etc., shall be provided where necessary.

Pipe hangers, supports, anchors, etc., shall be designed and fabricated to comply with part 5230.1030.

Statutory Authority: *MS s 326.46*

5230.0460 PIPE SLEEVES.

Where steam pipes pass through walls, partitions, floors, beams, etc., constructed of combustible material, protecting metal sleeves or thimbles shall be provided to give a clearance of not less than one-fourth inch under hot and cold conditions all around the pipe, or pipe and covering. When steam pipes pass through metal partitions, etc., a clearance of at least one-fourth inch under hot and cold conditions shall be left all around the pipe, or pipe and covering. In any

5230.0460 PIPEFITTERS; POWER PIPING SYSTEMS

5132

case, if the fluid temperature exceeds 250 degrees Fahrenheit, the pipe shall be insulated inside the sleeves with a covering of at least standard thickness.

Walls, floors, partitions, beams, etc., shall not be cast solidly to or built up around and in contact with a steam, hot water, or hot oil pipe. Where such pipe must be installed in a concrete floor or other building member, it shall be protected for the entire buried length with a suitable protecting pipe sleeve of steel, cast iron, wrought iron, or tile; exception may be taken to the preceding rules where pipes pass through walls, floors, partitions, etc., that must be kept water-tight.

Statutory Authority: *MS s 326.46*

5230.0470 DRAINS, DRIPS, AND STEAM TRAPS.

Subpart 1. Requirement. Suitable drains or drips shall be provided wherever necessary to drain the condensate from all sections of the piping and equipment wherever it may collect. Suitable drains shall also be provided to empty water lines, water storage tanks, equipment containing water, etc., when such piping and equipment is out of service. At least one valve shall be placed in each drip or drain line.

Subp. 2. Proper drainage. Drip lines from steam headers, mains, separators, and other equipment shall be properly drained by traps installed in accessible locations and below the level of the apparatus drained. Drip pumps, drip tanks, and open discharge drips (preferably with orifice control) may be used in lieu of traps, if they are safely installed, protected, and operated under regular supervision. All drain lines shall have drip valves for free blow to the atmosphere.

Subp. 3. Connections. Drip lines from steam headers, mains, separators, or other equipment operating at different pressures shall not be connected to discharge through the same trap. Where several traps discharge into one header which is or may be under pressure, a stop valve and a check valve shall be placed in the discharge line from each trap.

Subp. 4. Trap discharge piping. Trap discharge piping shall have the same thickness as the inlet piping unless it is vented to atmosphere or operated under low pressure and has no stop valves. The trap discharge piping shall have at least the pressure rating of the maximum discharge pressure to which it may be subjected. Trap discharge piping shall be protected against freezing where necessary. Drainage from steam traps, if open to the atmosphere, shall be safeguarded to prevent accidents from hot discharge.

Subp. 5. Trap discharge. The discharge of a high pressure trap shall not empty into a low pressure receiver unless first run through a flash tank or there is an ample sized vent so a trap failure could not increase the pressure in low pressure receiver tank.

Statutory Authority: *MS s 326.46*

5230.0480 INSPECTION AND TESTS.

All material shall be capable of meeting the inspection and test requirements described in the corresponding specification listed in Table 1 of ASA B31.1-1955. Unless otherwise specified by the purchaser, the manufacturer's certification that these tests have been met shall be accepted.

Statutory Authority: *MS s 326.46*

5230.0490 CLEANING.

The inside of all pipes, valves, and fittings shall be smooth, clean, and free from blisters, loose mill scale, sand, and dirt when erected. All lines should be cleaned after installation and before placing in service.

Statutory Authority: *MS s 326.46*

5230.0500 HYDROSTATIC TESTS.

Subpart 1. **Before erection.** All valves, fittings, etc. shall be capable of withstanding a hydrostatic shell test made before erection equal to twice the primary steam service pressure, except that steel fittings and valves shall be capable of withstanding the test pressures as given in the American Standard for Steel Pipe Flanges and Flanges Fittings ASA B16.5 for the specific material, pressure standard and facing involved (ring joint facing for welding ends). Pipe shall be capable of meeting the hydrostatic test requirements contained in the respective specifications in Table 1 ASA B31.1-1955, under which it was purchased.

Subp. 2. **After erection.** All piping systems shall be capable of withstanding a hydrostatic test pressure of one and one-half times the design pressure, except that the test pressure shall in no case exceed the adjusted pressure-temperature rating for 100 degrees Fahrenheit as given in the American Standard for Steel Pipe Flanges and Flange Fittings ASA B16.5 for the material and pressure standard involved. For systems joined wholly with welded joints the adjusted pressure rating shall be that for ring joint facing. For systems joined wholly or partly with flanged joints the adjusted pressure rating shall be that for the type of facing used.

The hydrostatic test after erection shall be applied wherever practicable and shall comply with part 5230.1070, subpart 10. In no case shall the test pressure be less than 50 psi nor shall it be made with a test medium having a temperature in excess of 100 degrees Fahrenheit.

Statutory Authority: *MS s 326.46*

5230.0510 THICKNESS OF PIPE.

For inspection purposes the minimum thickness of pipe wall required at different pressures and for temperatures shall not exceed those recommended by the manufacturer.

Statutory Authority: *MS s 326.46*

5230.0520 VARIATIONS IN PRESSURE AND TEMPERATURE.

Piping systems shall be considered safe for operation if the maximum sustained pressure and temperature on any part do not exceed the pressure and temperature allowed by this code, for all component parts of the system. It is recognized that occasional departures from the nominal operating pressure and temperature inevitably occur and therefore the piping system will also be considered safe for occasional operation for short periods at higher pressures and temperatures.

Either pressure or temperature, or both, may exceed the nominal design values if the computed stress in the pipe wall does not exceed the allowable S value for the expected temperature by more than the following allowances for the period of duration indicated:

A. up to 15 percent increase above the S value during 10 percent of the operating period;

B. up to 20 percent increase above the S value during one per cent of the operating period.

Statutory Authority: *MS s 326.46*

**SPECIFIC REQUIREMENTS; STEAM PRESSURES ABOVE 350 PSI
AND NOT ABOVE 2,500 PSI AND TEMPERATURES NOT IN EXCESS
OF 1,100 DEGREES FAHRENHEIT**

5230.0550 VALVES.

Subpart 1. **Nominal size.** All valves in nominal sizes three inches and smaller for pressures above 250 psi but not above 400 psi, two inches and smaller for pressures above 400 psi but not above 600 psi, and 1-1/2 inches and smaller for

5230.0550 PIPEFITTERS; POWER PIPING SYSTEMS

5134

pressures above 600 psi may have screwed, flanged, or welding ends. Stem threads of gate, angle, and globe valves of above sizes may be internal or external with reference to the valve bonnet.

Subp. 2. **Larger sizes.** For all valves larger than sizes specified in subpart 1 flanged or welding ends shall be used. Stem threads of gate, angle, and globe valves shall be external with reference to the valve body and used with an outside yoke. Bonnet joints may be flanged, welded, or of other designs, except that screwed bonnet connections which depend upon the thread to make a tight joint are not permitted. Steam valves eight inches and larger shall have a bypass of at least three-fourths inch nominal size. Sizes of bypasses should be increased if required for mechanical strength or vibration. Pipe for bypasses shall be seamless steel of a material at least equal to that used for the line. Pipe lighter than Schedule 80 of ASA B36.10 shall not be used for bypasses. Bypasses may be integral or attached.

Subp. 3. **Valve qualities.** All valves shall be manufacturer's standard, or equal for the respective pressure and temperature and shall be steel, or nonferrous material as recommended by the manufacturer and as stipulated in this code for this pressure-temperature range. Malleable iron valves may be used for service pressures not over 300 psi and temperatures not over 500 degrees Fahrenheit. Flanges of steel flanged valves shall comply with the American Standard B16.5 for respective pressure and temperature.

Statutory Authority: *MS s 326.46*

5230.0560 FITTINGS.

Subpart 1. **Nominal sized fittings.** All fittings in nominal sizes above three inches for pressures above 250 psi but not above 400 psi, two inches for pressures above 400 psi but not above 600 psi, and 1-1/2 inches for pressures above 600 psi but not above 2,500 psi shall have flanged ends or welding ends.

Subp. 2. **Flanged fittings.** Flanged fittings shall conform to the American Standard B16.5 for dimensions and for pressure and temperature ratings and shall be of cast or forged steel, but nonferrous materials may be used subject to limitations under part 5230.0320.

Subp. 3. **Welding fittings.** Welding fittings shall comply with American Standard for Steel Butt-Welding Fittings ASA B16.9 or American Standard for Steel Socket-Welding Fittings ASA B16.11 where applicable, and the material shall conform to ASTM Specifications A 216, A 217, or A 234, or material conforming to the requirements of part 5230.0320. Special fittings or welded assemblies fabricated in shop or field shall conform to this code. The material of special welding fittings shall conform to ASTM Specifications A 216, A 217, or A 234, or to the requirements of part 5230.0320. Special fittings or welded assemblies shall be construed to embrace cast, forged, rolled, or extruded fittings of special dimensions, and built-up manifolds, segmental elbows, fabricated swages, orange-peel bull plugs, or any similar construction not covered by American Standards B16.9 or B16.11 for factory-made welding fittings.

Subp. 4. **Forged- or cast-steel screwed fittings.** Forged- or cast-steel screwed fittings are permitted in small nominal sizes up to and including three inches for pressures above 250 psi but not above 400 psi, two inches for pressures above 400 psi but not above 600 psi, and 1-1/2 inches for pressures above 600 psi but not above 2,500 psi if their design is suitable for the pressure and temperature. Malleable iron screwed fittings conforming to the 300-pound American Standard B16.19 may be used for pressures not over 300 psi if the temperature is not over 500 degrees Fahrenheit.

Statutory Authority: *MS s 326.46*

5230.0570 PIPE JOINTS.

Flanges and bolting shall conform to the American Standard B16.5 for

MINNESOTA RULES 1991

5135

PIPEFITTERS; POWER PIPING SYSTEMS 5230.0610

respective pressures and temperatures. Unions shall be forged steel and suitable for the pressure or malleable iron to the AAR Specification M404. For joints other than welded, refer to part 5230.1050. Welded joints shall be constructed as detailed under part 5230.1070 and welding operators shall qualify according to part 5230.1080.

Statutory Authority: *MS s 326.46*

5230.0580 PIPE.

Subpart 1. Pressures greater than 600 psi. For pressures above 600 psi, the pipe shall be:

- A. seamless steel meeting ASTM Specifications A 106, A 312, A 335 or A 376; or
- B. forged and bored steel meeting A 369; or
- C. automatic welded steel meeting A 312; or
- D. electric-fusion-welded steel pipe meeting with ASTM Specification A 155.

Subp. 2. Pressures greater than 250 psi. For pressures above 250 psi, but not above 600 psi, pipe shall be:

- A. seamless steel in accordance with ASTM Specification A 106;
- B. electric-fusion-welded steel pipe in accordance with ASTM Specification A 155;
- C. electric-resistance-welded steel pipe of ASTM Specification A 135; or
- D. seamless or electric-resistance-welded steel pipe of ASTM Specification A 53.

Subp. 3. Pressures less than 250 psi. For service up to 750 degrees Fahrenheit and pressures of not over 250 psi, any of the following classes of pipe may be used:

- A. electric-fusion-welded steel pipe of ASTM Specification A 134, or A 139;
- B. electric-resistance-welded steel pipe of ASTM Specification A 135;
- C. seamless or welded steel pipe of ASTM Specification A 53; or
- D. wrought iron pipe of ASTM Specification A 72.

Pipe permissible for the service specified in subpart 3 may be used for temperatures higher than 750 degrees Fahrenheit, unless otherwise prohibited, if the S value in accordance with part 5230.0510 is used when calculating the pipe wall thickness.

Statutory Authority: *MS s 326.46*

5230.0590 PIPES FOR SPECIAL USES.

Grade A seamless steel pipe of ASTM Specification A 106, wrought iron pipe of ASTM A 72, Grade A seamless steel pipe of ASTM A 53, or Grade A electric-welded pipe of ASTM A 53, A 135, or A 139 shall be used for close coiling, cold bending, or other special uses.

Statutory Authority: *MS s 326.46*

5230.0600 OTHER PIPE PERMITTED.

Pipe meeting API Specification 5L may also be used. See part 5230.0320.

Statutory Authority: *MS s 326.46*

5230.0610 BOLTING.

Bolting shall conform to ASTM Specification A 193. Nuts shall conform to ASTM Specification A 194. See part 5230.0390.

Statutory Authority: *MS s 326.46*

STEAM PRESSURES ABOVE 125 PSI AND NOT ABOVE 250 PSI AND TEMPERATURES NOT IN EXCESS OF 450 DEGREES FAHRENHEIT**5230.0650 VALVES.**

Gate, angle, and globe valves three inches and smaller may have inside screw. All stop valves eight inches and over shall be bypassed. Pipe used in a bypass shall be of steel or wrought iron. All gate valves larger than three inches shall have outside screw and yoke where clearance permits. Where clearance is insufficient, nonrising stem gate valves are permissible but it is recommended an indicator be required where lack of one would be a hazard.

All valves shall be manufacturer's standard or equal for the specified pressure and temperature. Bodies, bonnets, and yokes shall be of cast iron, malleable iron, steel, bronze, brass, nickel, or nickel alloy. Drilling and facing of flanges of flanged valves shall comply with American Standard B16b, B16.5 (for 150-pound steel), or B16.24 (for bronze).

Statutory Authority: MS s 326.46

5230.0660 FITTINGS.

Subpart 1. **General requirement.** Fittings shall be of steel, cast iron, malleable iron, bronze, or brass.

Subp. 2. **Flanged steel fittings.** Flanged steel fittings shall conform to the requirements for 300-pound fittings in the American Standard B16.5, except that the 150-pound fittings conforming to the American Standard B16.5 may be used for the adjusted pressure-temperature ratings established therein.

Subp. 3. **Welding fittings.** Welding fittings shall comply with American Standard for Steel Butt-Welding Fittings (B16.9) or American Standard for Steel Socket-Welding Fittings (B16.11) where applicable, and the material shall conform to ASTM Specifications A 216, A 217, or A 234 or material conforming to the requirements of part 5230.0320. Special fittings or welded assemblies fabricated in shop or field shall conform to this code. The material of special welding fittings shall conform to ASTM Specifications A 216, A 217, or A 234, or to the requirements of part 5230.0320. Special fittings or welded assemblies shall be construed to embrace cast, forged, rolled, or extruded fittings of special dimensions, and built-up manifolds, segmental elbows, fabricated swages, orange-peel bull plugs, or any similar construction not covered by American Standards B16.9 or B16.11 for factory-made welding fittings.

Subp. 4. **Cast-iron fittings.** Flanged cast-iron fittings shall conform to the Class 250 American Standard B16b and may be used for the pressure and temperature ratings established therein. Screwed cast-iron fittings shall conform to the 250-pound American Standard B16.4.

Subp. 5. **Malleable iron fittings.** Screwed malleable iron fittings shall conform to the 300-pound American Standard B16.19 except that 150-pound malleable iron fittings conforming to the American Standard B16.3 may be used for pressures not in excess of 150 psi.

Subp. 6. **Brass or bronze fittings.** Flanged brass or bronze fittings shall conform to the 300-pound American Standard B16.24, except that 150-pound brass or bronze fittings conforming to B16.24 may be used for pressure not in excess of 150 psi.

Screwed brass or bronze fittings shall conform to the 250-pound American Standard B16.17.

Statutory Authority: MS s 326.46

5230.0670 PIPE JOINTS.

Steel flanges and bolting shall conform to the 300-pound American Standard B16.5. Cast iron flanges shall conform to the Class 250 American Standard B16b for the pressure and temperature ratings established in the standard. Bronze

MINNESOTA RULES 1991

5137

PIPEFITTERS; POWER PIPING SYSTEMS 5230.0760

flanges and bolting shall conform to the 150-pound and 300-pound American Standard B16.24 for the respective pressures and temperatures. The 150-pound American Standard B16.5 may be used if permitted by its table of adjusted pressure-temperature ratings. Unions shall be suitable for the pressure. For joints other than welded, refer to part 5230.1050, subpart 2. Welded joints shall be constructed as detailed under part 5230.1070 and welding operators shall qualify according to part 5230.1100.

Statutory Authority: *MS s 326.46*

5230.0680 PIPE.

For pressures and temperatures within this specific requirement group, any of the following classes of pipe may be used:

- A. electric-fusion-welded steel pipe of ASTM Specification A 134, or A 139;
- B. electric-resistance-welded steel pipe of ASTM A 135;
- C. seamless or welded steel pipe of ASTM Specification A 53; or
- D. wrought iron pipe of ASTM Specification A 72.

Copper pipe or tubing and brass pipe may be used for this class of service provided the temperature is not above 406 degrees Fahrenheit.

Grade A seamless steel pipe of ASTM Specification A 53, or wrought iron pipe of ASTM Specification A 72, or Grade A electric-welded pipe of ASTM A 53, A 135, or A 139 shall be used for close coiling, cold bending, or other special uses.

The foregoing shall not exclude cast-iron pipe if it conforms to the specifications and pressure-temperature ratings in this section of the code.

Pipe permissible for the above service may be used for temperatures higher than 450 degrees Fahrenheit, unless otherwise prohibited, if an S value in accordance with part 5230.0510 is used.

Pipe meeting API Specifications 5L may also be used. See part 5230.0320.

Statutory Authority: *MS s 326.46*

5230.0690 BOLTING.

Bolting material shall be of steel. Carbon steel bolts and bolt-studs purchased under a definite specification may be able to resist calculated stresses for piping systems up to 250 psi and temperatures of 450 degrees Fahrenheit, but for pressures in excess of 160 psi, ASTM Specification A 193 is recommended for bolting material, except that where cast-iron flanges are used bolting material shall be of carbon steel. Nuts shall meet ASTM Specification A 194.

Statutory Authority: *MS s 326.46*

STEAM PRESSURES ABOVE 25 PSI BUT NOT ABOVE 125 PSI AND TEMPERATURES NOT IN EXCESS OF 450 DEGREES FAHRENHEIT

5230.0750 VALVES.

All valves shall be manufacturer's standard for the specified pressure and shall have cast-iron, malleable iron, steel, or brass bodies, bonnets, disks, and yokes. Drilling and facing of flanges of flanged valves shall conform with American Standard B16.1 or B16.24.

Statutory Authority: *MS s 326.46*

5230.0760 FITTINGS.

Subpart 1. **General requirement.** Fittings shall be of steel, cast iron, malleable iron, bronze, or brass.

Subp. 2. **Flanged steel fittings.** Flanged steel fittings shall conform to the requirements for 150-pound fittings in the American Standard B16.5.

Subp. 3. Welding fittings. Welding fittings shall comply with American Standard for Steel Butt-Welding Fittings (B16.9) or American Standard for Steel Socket-Welding Fittings (B16.11) where applicable, and the material shall conform to ASTM Specifications A 216, A 217, or A 234, or material conforming to the requirements of part 5230.0320. Special fittings or welded assemblies fabricated in shop or field shall conform to this code. The material of special welding fittings shall conform to ASTM Specifications A 216, A 217, or A 234, or to the requirements of part 5230.0320. Special fittings or welded assemblies shall be construed to embrace cast, forged, rolled, or extruded fittings of special dimensions, and built-up manifolds, segmental elbows, fabricated swages, orange-peel bullplugs, or any similar construction not covered by American Standards B16.9 or B16.11 for factory-made welding fittings.

Subp. 4. Cast-iron fittings. Flanged cast-iron fittings shall conform to the Class 125 American Standard B16.1 and may be used for the pressure and temperature ratings established therein. Screwed cast-iron fittings shall conform to the 125-pound American Standard B16.4.

Subp. 5. Screwed malleable iron fittings. Screwed malleable iron fittings shall conform to the 150-pound American Standard B16.3.

Subp. 6. Brass or bronze fittings. Flanged brass or bronze fittings shall conform to the 150-pound American Standard B16.24. Screwed brass or bronze fittings shall conform to the 125-pound American Standard B16.15.

Statutory Authority: *MS s 326.46*

5230.0770 PIPE JOINTS.

Steel flanges shall conform to the 150-pound American Standard B16.5. Cast-iron flanges and bolting shall conform to the Class 125 American Standard B16.1 for the pressure and temperature ratings established in the standard. Bronze flanges and bolting shall conform to the 150-pound American Standard B16.24. Unions shall be suitable for the pressure and temperature. For joints other than welded refer to part 5230.1050, subpart 2. Welded joints shall be constructed as detailed under part 5230.1070. Welding operators shall qualify according to part 5230.1070. Cast-iron pipe joints may be welded with bronze, nickel, or nickel alloy, or 18 Cr-8 Ni electrodes, if the temperature is not over 353 degrees Fahrenheit.

Statutory Authority: *MS s 326.46*

5230.0780 PIPE.

Pipe shall be of steel, wrought iron, cast iron, copper, or brass subject to the limitations given in part 5230.0510. Steel pipe meeting ASTM Specification A 120 may be used except for close coiling or bending.

Statutory Authority: *MS s 326.46*

5230.0790 BOLTING.

Bolting material shall be of carbon steel or wrought iron threaded in accordance with American Standard for Screw Threads B1.1, coarse thread series.

Statutory Authority: *MS s 326.46*

STEAM PRESSURES 25 PSI AND BELOW AND TEMPERATURES NOT IN EXCESS OF 450 DEGREES FAHRENHEIT

5230.0850 VALVES.

All valves shall be of the manufacturers' standard for 25 psi pressure and shall have cast-iron, malleable iron, or brass bodies, bonnets, disks, and yokes. Flanges of flanged valves shall conform to the 25-pound American Standard B16B2 for pipe sizes four inches and above and to the 125-pound American Standard B16.1 for sizes under four inches, or to American Standard B16.24.

Statutory Authority: *MS s 326.46*

MINNESOTA RULES 1991

5139

PIPEFITTERS; POWER PIPING SYSTEMS 5230.0950

5230.0860 FITTINGS.

Subpart 1. **Minimum requirements.** For minimum requirements fittings shall be of cast iron, malleable iron, or other material allowed under this code.

Subp. 2. **Cast iron.** Flanged cast-iron fittings shall conform to the 25-pound American Standard B16b2. Screwed cast-iron fittings shall conform to the 125-pound and 250-pound American Standard B16.4.

Subp. 3. **Malleable iron.** Screwed malleable iron fittings shall conform to the 150-pound American Standard B16.3.

Subp. 4. **Brass or bronze.** Screwed brass or bronze fittings shall conform to the 125-pound American Standard B16.15.

Subp. 5. **Steel.** Welding fittings shall comply with American Standard for Steel Butt-Welding Fittings B16.9 or American Standard for Steel Socket-Welding Fittings B16.11 where applicable, and the material shall conform to ASTM Specifications A 216, A 217, or A 234, or material conforming to the requirements of part 5230.0320. Special fittings or welded assemblies fabricated in shop or field shall conform to this code. The material of special welding fittings shall conform to ASTM Specifications A 216, A 217, or A 234, or to the requirements of part 5230.0320. Special fittings or welded assemblies shall be construed to embrace cast, forged, rolled, or extruded fittings of special dimensions, and built-up manifolds, segmental elbows, fabricated swages, orange-peel bull plugs, or any similar construction not covered by American Standards B16.9 or B16.11 for factory-made welding fittings.

Statutory Authority: *MS s 326.46*

5230.0870 PIPE JOINTS.

For minimum requirements cast-iron flanges shall conform to the 25 psi American Standard B16b2. Companion flanges shall conform to Class 125 American Standard B16.1. Bronze flanges shall conform to 150-pound American Standard B16.24. Unions when used shall be suitable for the pressures. For joints other than welded, refer to part 5230.1050, subpart 2. Screwed joints may be used for pipe sizes as detailed under part 5230.1050, subpart 2. Welded joints shall be constructed as detailed under part 5230.1070 and welding operators shall qualify according to part 5230.1070, subpart 2. Cast-iron pipe joints for this class of service may be welded with bronze, nickel, or nickel alloy, or 18 Cr-8 Ni electrodes, if the temperature is not over 353 degrees Fahrenheit.

Statutory Authority: *MS s 326.46*

5230.0880 PIPE.

Pipe shall be of steel, wrought iron, brass, copper, or cast iron. For limitations on copper pipe and tube and brass pipe, see part 5230.0960, subpart 7.

Statutory Authority: *MS s 326.46*

5230.0890 BOLTING.

Bolting material shall be of steel or wrought iron.

Statutory Authority: *MS s 326.46*

5230.0950 BOILER FEED SYSTEMS AND OTHER WATER PIPING NOT OTHERWISE COVERED.

Subpart 1. **Requirements.** The following requirements shall apply to all boiler feed systems and systems for water, except that on boiler feed systems the piping from the boiler drum or equivalent point to and including the feed valves required by ASME Boiler and Pressure Vessel Code.

Subp. 2. **Highest pressure and temperature.** Hot water systems shall be designed for the highest pressure and temperature actually existing in the piping under normal operation.

Boiler feed piping systems shall be designed for the highest pressure exerted by the boiler feed pumps at any load under normal operation and on the highest corresponding temperature, actually existing. Where water passes through heaters in series, the temperature rating of the piping shall conform to the actual temperatures produced by the heaters in each part of the system; but in no case shall pipe or fitting be rated less than 1.25 times the safety valve setting on the boiler.

Statutory Authority: *MS s 326.46*

5230.0960 BOILER FEED PIPING.

Subpart 1. Two means of feeding water. Boilers having more than 500 square feet of water heating surface shall have at least two means of feeding water. Each source shall be capable of supplying water to the boiler at a pressure of six percent higher than the highest setting of any safety valve on the boiler. For boilers that are fired with solid fuel not in suspension, one source of feeding shall be steam operated.

Subp. 2. Check valve and globe valve or plug cock. The feed pipe to the boiler or boilers shall be provided with a check valve and at least one globe valve or plug cock. The stop or globe valve to be placed between the check valve and boiler and when a globe valve is used, the water inlet shall be under the disk.

Subp. 3. Pressure requirement. All valves and fittings on the feed water piping from the pump to the boiler including the stop and check valves shall be equal at least to the requirement of the American Standards for a pressure 1.25 times the maximum allowable working pressure of the boiler or 1.25 times the lowest set pressure of any safety valve in the boiler drum, except as otherwise provided in the ASME Boiler Code or American Standards Association.

Subp. 4. Materials. Valves and fittings made of any material permitted by the code for pressure rating of 125 pounds or more and marked as required by the code may be used for feed line and blowoff service up to 80 percent of the rated pressure, except where certain materials are specified, and in no case shall they be used for temperatures exceeding that permitted by the code.

Subp. 5. Design. Where the pressure and temperature requirements of the feed piping system, as defined in part 5230.0950 fall within the scope of part 5230.0610, inclusive, the feed piping system shall be designed in accordance with these paragraphs but flanges, fittings, and valves may be selected in accordance with the adjusted pressure-temperature ratings given in the American Standard for Steel Pipe Flanges and Flange fittings B16.5. Where the requirements of the feed piping system or hot water piping, as defined in part 5230.0950, fall within the scope of parts 5230.0650 to 5230.0690 and parts 5230.0750 to 5230.0790, inclusive, the entire piping system including fittings and flanges shall conform to or at least be equal to the steam piping requirements in parts 5230.0650 to 5230.0690 and parts 5230.0750 to 5230.0790.

All pressures and temperatures specified in parts 5230.0950 and 5230.0960 refer to continued normal operation. For short time operation excess pressures and temperatures may be allowed as specified in part 5230.0520.

Subp. 6. Bypasses. No bypasses around valves shall be required for pressures under 600 psi. For pressures 600 psi and above, it is recommended that all valves eight inches and over in size be equipped with a bypass of at least three-fourths inch nominal size.

Subp. 7. Exceptions. Brass or copper pipe and tube may be used where a temperature of 406 degrees Fahrenheit is not exceeded.

Cast-iron pipe may be used where a pressure of 300 psi or a temperature of 450 degrees Fahrenheit is not exceeded.

Statutory Authority: *MS s 326.46*

5230.0970 BLOWOFF PIPING AND TANKS.

Subpart 1. **Classification.** The following requirements for blowoff piping apply to the entire system beyond the blowoff valves on the boiler to the blowoff tank or other point where the pressure is reduced approximately to atmospheric and cannot be increased by closing a valve. However, boiler blowoff piping that may be subjected to full boiler pressure, shall be capable of withstanding full boiler pressure.

Subp. 2. **Design.** Blowoff piping shall be designed as for saturated steam in accordance with the following table, but all fittings shall be of steel.

A. Steel fittings shall be used on the blowoff piping between the boiler and the blowoff valves when the pressure exceeds 100 psi. All pipe connections between the boiler and the blowoff tank shall be made as direct as possible using sweep bends having a radius of four times the diameter of the pipe. Where conditions make the use of sweep bends prohibitive, long sweep fittings that comply with the standards of blowoff fittings set out in the ASME Power Code may be used.

B. The inlet shall enter the shell at a tangent and shall be above the surface of the water in the tank. A wearing plate shall be attached to the inside of the shell opposite the inlet opening.

C. The outlet opening shall be connected with internal pipe or baffle extending downward to within a few inches of the bottom of the tank. A three-fourth inch syphon breaker shall connect the outlet piping with the vent pipe.

Subp. 3. Recommended pipe sizes for blowoff systems up to 450 pounds.

Blowoff Inlet	Water Outlet	Vent
* 3/4	3/4	2
1	1	2-1/2
1-1/4	1-1/4	3
1-1/2	1-1/2	4
2	2	5
2-1/2	2-1/2	6

*For boilers of 100 square feet of heating surface or less.

A. The blowdown from any boiler shall not be connected directly to any sanitary sewer system. The blowdown must first pass through a blowoff tank or other apparatus that will reduce the pressure to not more than five pounds and the temperature to not more than 180 degrees Fahrenheit.

B. All piping between the boiler and blowoff valve on pressures exceeding 100 pounds shall be of double strength. Galvanized pipe or fittings shall not be used.

C. When the pressure exceeds 100 pounds, two blowoff valves shall be used, at least one valve shall be of the slow opening type.

D. Globe valves or gate valves are not to be used on new installations unless such globe or gate valves are designed for blowoff service.

E. Blowoff tanks shall be installed in such a manner that inspection can be made of any part of the tank at all times.

F. Blowoff tanks placed underground shall be installed in a properly walled pit with a space of not less than 18 inches between the tank and wall, and not less than 12 inches between the tank and the floor.

G. The end of the blowoff pipe from any steam boiler or the vent pipe from any blowoff tank or other apparatus shall not terminate in any location where the discharge can endanger the life or limb of any person or the property in which any such apparatus is located.

H. The state plumbing code provides: "The exhaust, blowoff, sediment, or drip pipe from any steam boiler or steam trap shall not be connected directly

5230.0970 PIPEFITTERS; POWER PIPING SYSTEMS

5142

to any sewer, drain, soil waste, or vent pipe. The water or steam of condensation from such pipe before it shall enter any sewer or drain shall be discharged into a suitable catch basin or condenser." The foregoing section is adopted and made a part of this code.

Statutory Authority: *MS s 326.46*

5230.0980 WATER COLUMN.

Crosses shall be used on all right angle turns on the piping to the water column. The minimum size pipe connecting the water column to the boiler shall be not less than one inch in diameter.

No pipe connections may be made on the water column piping except those connected to equipment or appurtenances used to measure, record, or regulate. This would include steam gauge, low water cutoff, pressure controls, pump controls, etc. Not included would be such equipment as whistles or soot blowers.

Cast-iron plugs shall not be used in crosses. Galvanized pipe or galvanized fittings shall not be used on any connection directly to the boiler.

If any valves are used between the water column and boiler, they shall be of the straight way type with either a lever or rising stem and shall be sealed open.

On power boilers where pressures exceed 100 pounds, two valves shall be used on the blowoff pipe on the water column, one of which shall be of the plug type with gland and shall be installed as close to the water column as possible.

Statutory Authority: *MS s 326.46*

5230.0990 SAFETY VALVES.

Subpart 1. Required number. Each boiler shall have at least one safety valve and if it has more than 500 square feet of water heating surface, it shall have two or more safety valves.

Subp. 2. Two or more valves. When two or more safety valves are used on a boiler, they may be mounted either separately or as twin valves made by placing individual valves on Y bases, or duplex valves having two valves in the same body casing. Twin valves in the same body shall be the same size.

Subp. 3. Connection. The safety valve or valves shall be connected to the boiler independent of any other steam connection, and attached as close as possible to the boiler, without any unnecessary intervening pipe or fitting. Every safety valve shall be connected so as to stand in an upright position, with spindle vertical.

Subp. 4. Placement. No valve of any description shall be placed between the required safety valve or valves and the boiler, nor on the discharge pipe between the safety valve and the atmosphere. When a discharge pipe is used, the cross-sectional area shall be not less than the full area of the outlet. All safety valve discharges shall be so located or piped as to be carried clear from running boards or platforms. If the discharge pipe is more than ten feet in length, the diameter of the pipe should be increased to the next size to relieve any back pressure on the safety valve. If the discharge pipe runs in both a horizontal and vertical position, it shall be pitched away from the valve and properly drained.

Subp. 5. Vertical position. When a safety valve discharge pipe runs in a vertical position it should be supported with proper hangers in such a manner as to avoid any vibration or undue stress on the safety valve, and also provisions must be made to drain any collection of condensate so it will not accumulate above the seat of the safety valves. It is recommended that drip pan elbows be used whenever possible to drain accumulation of condensation from relief valves.

Statutory Authority: *MS s 326.46*

5230.1000 STEAM PIPING.

When boilers are connected to a common steam main, the steam connection

from each boiler having a manhole opening shall be fitted with two stop valves having an ample free blow drain between them. The discharge of this drain shall be visible to the operator while manipulating the valve. The stop valves shall consist preferably of one automatic nonreturn valve set next to boiler and a second valve of the outside-screw-and-yoke type; or, two valves of the outside-screw-and-yoke type shall be used.

When pressure reducing valves are used, one or more relief or safety valves shall be provided on the low pressure side of the reducing station in the event that the piping or equipment on the low pressure side does not meet the requirements for the full initial pressure. Proper protection shall be provided to prevent possible injury or damage caused by the discharge from the safety valves. The relief or safety valves shall be installed as close to the reducing valves as possible. It is mandatory that a pressure gage be installed on the low pressure side of the reducing valve.

Statutory Authority: *MS s 326.46*

5230.1010 SERVICE WATER AND CONDENSING WATER SYSTEMS.

Subpart 1. Above 175 psi but not above 400 psi. Service water piping systems above 175 psi but not above 400 psi shall be designed as prescribed for 250 psi saturated steam pressure in parts 5230.0650 to 5230.0690, except that for valves, the manufacturer's rating shall be adhered to for the service pressure.

Subp. 2. Above 43 psi but not above 175 psi. Service water piping systems above 43 psi but not above 175 psi shall be designed as prescribed for 125 psi saturated steam pressure in parts 5230.0750 to 5230.0790.

Subp. 3. 43 psi and below. Condensing water and service water systems up to and including 43 psi pressure shall be designed as prescribed for 25 psi saturated steam pressure in parts 5230.0850 to 5230.0890. Bell and spigot joints may be used if permitted by part 5230.1050.

Subp. 4. Bypasses. No bypasses around valves shall be required.

Subp. 5. Welding. Welding operators for work on service water and condensing water systems shall qualify according to part 5230.1070.

Statutory Authority: *MS s 326.46*

5230.1020 INSTRUMENT AND CONTROL PIPING.

Subpart 1. Scope. These requirements shall apply to the design of instrument and control piping for safe and proper operation of the piping itself. They do not cover design of piping to secure proper functioning of instruments for which the piping is installed.

The term "instrument piping" shall apply to all valves, fittings, tubing, and piping used to connect instruments to main piping or to other instruments or apparatus or to measuring equipment as used within the classification of part 5230.0260.

The term "control piping" shall apply to all valves, fittings, tubing, and piping used to interconnect air or hydraulically operated control apparatus also classified in accordance with part 5230.0260 as well as to interconnect instrument transmitters and receivers.

"Sampling piping" shall apply to all valves, fittings, tubing, and piping used for the collection of samples of steam, water, and oil. It shall conform to minimum requirements for the main line to which it connects.

This paragraph does not include tubing used in permanently closed systems, such as fluid-filled temperature responsive devices.

Subp. 2. Materials and design. The materials employed for valves, fittings, tubing, and piping shall meet the particular conditions of service and the requirements of the applicable specifications listed under general parts 5230.0320 to 5230.0350, with allowable stresses.

Subp. 3. Takeoff connections. Takeoff connections at the source together with attaching bosses or adapters when used shall be made of material at least equivalent to that of the pipe or vessel to which they are attached. They shall be designed to withstand full line pressure and temperature and all stresses including those induced by fatigue, without failure. The nominal pipe size of the takeoff connections shall be not less than one-half inch for service conditions not in excess of either 900 psi or 800 degrees Fahrenheit, and three-fourths inch nominal pipe size (for adequate physical strength) for conditions which exceed either of these limits.

To prevent overstressing the main stream line by contact with the colder condensate return from the instrument, steam meter, or instrument takeoff connections shall be lagged in with the steam main. For temperatures in excess of 800 degrees Fahrenheit they may also be arranged to make metallic contact lengthwise with the steam main.

Bosses or adapters may be used for temperatures not exceeding 800 degrees Fahrenheit, provided the hole drilled through the pipe wall is the same diameter as the inside diameter of the takeoff connections. For higher temperatures the adapter may be provided with a thermal sleeve which extends entirely through the pipe wall.

Subp. 4. Main line shutoff valves. Shutoff valves shall be provided at the end of takeoff connections. They shall be capable of withstanding the maximum working pressure and temperature of the piping system to which the takeoff nipples are attached.

Subp. 5. Reservoirs or condensers. In dead end steam service, and optionally for other services, condensing reservoirs, and connecting nipples which immediately follow the main line shutoff valves, shall be made of low carbon steel or other suitable material for the saturated steam temperature corresponding to the actual line pressure.

Subp. 6. Connecting tubing or piping. For instruments between shutoff valves and instrument:

A. Copper, copper alloys, and other nonferrous materials, may be used in dead end steam, water, oil, and similar services up to the maximum main line pressures and temperatures provided that the temperature within the connecting lines for continuous service does not exceed 406 degrees Fahrenheit. Where condensers are used of a design such that they are filled with part steam and part water so that the temperature of the water in the reservoir is above 406 degrees Fahrenheit, a five-foot length of uninsulated steel tubing shall immediately follow the condenser, ahead of the connecting copper tubing to the instrument.

B. For higher pressures and temperatures steel or alloy steel may be used up to the maximum.

C. The minimum size of the tubing or piping is a function of its length, the volume of fluid required to produce full scale deflection of the instrument, and the service of the instrument. When required to prevent plugging as well as to obtain sufficient mechanical strength, the inside diameter of the pipe or tube should not be less than 0.36 inch, with a wall thickness of not less than 0.049 inch. When these requirements do not apply, smaller sizes with wall thickness in due proportion, may be used.

D. The piping shall be designed in accordance with part 5230.0510, with due allowance for water hammer when required. Unless required by corrosive conditions however, the factor "C" need not apply. In view of the absence of proper standards on the matter, the hardness of the tubing used should conform to the specifications established by the manufacturer of the fittings to be used.

For control: the same materials may be used for control piping as for instrument piping except that the minimum inside diameter shall be 0.178 inch instead of 0.36 inch, with a minimum wall thickness of 0.028 inch.

MINNESOTA RULES 1991

5145

PIPEFITTERS; POWER PIPING SYSTEMS 5230.1030

Subp. 7. Other valves. Blowdown valves at or near the instrument shall be of the gradual opening type and for steam service shall be suitable for saturated steam temperature corresponding to the actual line pressure. For other than steam service they shall be suitable for the actual main line pressure and temperature.

When blowdown valves are used, valves at the instrument as well as any intervening fittings and tubing between such blowdown valves and the meter, may be suitable only for 1-1/2 times the design pressure at 100 degrees Fahrenheit. When blowdown valves are not used, instrument valves shall conform to the requirements of the first paragraph of this subpart.

Subp. 8. Fittings and joints. For dead-end steam service and for water above 100 degrees Fahrenheit, steel fittings of the flared or socket welded types, part 5230.1130, subpart 2, items A and C, or other suitable types of similar design shall be used in accordance with the pressure-temperature conditions given in the chart in this section.

Subp. 9. Special safety provisions. Connecting piping subject to clogging from solids or deposits shall be provided with suitable connections for cleaning. Connecting piping handling air and gases containing moisture or other extraneous materials shall be provided with suitable drains or settling chambers or traps in accordance with part 5230.0470. Connecting piping to which may contain liquids shall be protected from damage due to freezing by heating or other adequate means.

Subp. 10. Supports. Supports shall be furnished as specified in part 5230.0450 not only for safety but also to protect the piping against detrimental sagging, external mechanical injury, abuse, and exposure to unusual service conditions.

Subp. 11. Installation. Instrument and control piping shall be inspected and tested in accordance with parts 5230.0480 and 5230.0500, and cleaned as specified in part 5230.0490.

Statutory Authority: *MS s 326.46*

5230.1030 FABRICATION OF PIPE HANGERS, SUPPORTS, ANCHORS, SWAY BRACINGS, AND VIBRATION DAMPENERS.

Subpart 1. General materials requirements. All materials used in the fabrication of equipment included in this chapter of the code shall be capable of meeting the general requirements designated herein. The dimensions and the physical and chemical characteristics of these materials shall be chosen so that the factors of safety, under the operating conditions, are not less than those specified herein under part 5230.1040, subpart 8. Construction equal to or better than required by this code is mandatory, including the use of materials having physical and chemical properties at least equal to its minimum requirements.

Subp. 2. Materials standards. The policy of the sectional committee in making reference to standards and specifications is stated in part 5230.1120, subpart 4. All materials used shall be capable of meeting the respective standard specifications given in part 5230.0320.

Subp. 3. Specific material requirements. All equipment for permanent hangers, supports, and anchors shall be fabricated from durable materials for the service conditions involved.

In tunnels and in buildings of fireproof construction, the use of wood and wire for piping supports shall be limited to rigging and temporary supports during erection. All permanent supports shall be fabricated from noncombustible materials.

In buildings of nonfireproof construction and in areas outside of buildings, piping may be supported by or hung from wooden structures provided that all piping used for conveying fluids at a temperature above 230 degrees Fahrenheit

shall be spaced for insulated from such wooden members to prevent dangerous heating.

Steel or wrought iron, except as provided in subpart 3 and part 5230.1040, subparts 2 to 4, shall be used throughout in the fabrication of hanger rods, turnbuckles, beam clamps, pipe clamps, and straps, chains, supports, rollers, guides, bases, and all other parts used for the support of piping. Parts of supports which are subjected principally to bending or tension loads, and which are subjected to working temperatures for which carbon steel is not recommended, shall be made of suitable alloy steel.

Statutory Authority: *MS s 326.46*

5230.1040 SPACING BETWEEN PIPE SUPPORTS.

Subpart 1. **Maximum spacing.** Suggested maximum spacing between pipe supports for straight runs of standard wall pipe and heavier pipe at maximum operating temperature of 750 degrees Fahrenheit.

(Does not apply where there are concentrated loads between supports, such as flanges, valves, specialties, etc.)

Nominal Pipe Size Inches	Maximum Span Feet
1	7
1-1/2	9
2	10
2-1/2	11
3	12
3-1/2	13
4	14
5	16
6	17
8	19
10	22
12	23
14	25
16	27
18	28
20	30
24	32

The above spacing based on a combined bending and shear stress of 1500 psi when pipe is filled with water and the pitch of the line is such that a sag of 0.1 inch between supports is permissible.

Subp. 2. **Cast iron.** Cast iron may be used for the fabrication of roller bearing bases, rollers, guides, anchor bases, brackets, and parts of piping supports upon which the loading will be mainly that of compression. Cast iron shall not be used for hanger rods, turnbuckles, clamps, or any parts which will be subjected principally to tension loads.

Subp. 3. **Malleable iron castings.** Malleable iron castings of suitable design may be used for pipe clamps, beam clamps, hanger flanges, clips, bases, swivel rings, and parts of pipe supports but their use shall be limited to such cases where the malleable iron will not be within a distance of 12 inches from piping subjected to temperatures of 450 degrees Fahrenheit.

Subp. 4. **Corrosion resistant metals.** Nonferrous metals or corrosion-resisting steel alloys should be used for equipment to support piping under conditions causing excessive corrosion of ordinary steel or wrought iron. Cast iron or malleable iron castings, if warranted as a protection against the expected corrosion, also

MINNESOTA RULES 1991

5147

PIPEFITTERS; POWER PIPING SYSTEMS 5230.1040

may be used but their use shall be subject to the requirements of subparts 2 and 3.

Subp. 5. Protective coatings. Under conditions causing atmospheric rusting or slight corrosion, corrosion-resisting materials need not be used, but a protective coating such as a hot dipped galvanizing, a weather-resisting paint, or other suitable protection shall be applied after fabrication to all parts where required. Under conditions causing mild corrosion such as atmospheric rusting, which are not of an intensity to warrant the use of corrosion-resistant materials, a durable protective coating such as hot-dipped galvanizing, weather resisting paint or other suitable protection should be applied to all parts after fabrication or after installation.

Under any conditions, exposed screw threads on parts of this equipment where corrosion-resisting materials are not used shall be greased immediately after fabrication. Paints, slushes, or other suitable protective coatings may be used instead of grease.

Subp. 6. General limitations. The following limitations apply:

A. Supports shall prevent excessive variation of supporting effort, and possible resonance with imposed vibrations. The construction shall also be such that complete release of the piping load will be impossible in the case of spring failure or misalignment.

B. The fabrication of helical and elliptical springs for spring hangers and supports shall be in accordance with the respective specifications. Springs shall be fabricated so that the proper working fiber stress, depending upon the type of spring and the service for which it is intended, shall not be exceeded.

C. All parts of the supporting equipment shall be fabricated and assembled so that they will not be disengaged by movement of the supported piping.

D. Pipe, straps, or bars of strength equal to the equivalent hanger rod may be fabricated for use instead of hanger rods.

E. Hangers used for the support of piping of two inch minimal pipe size and larger shall be fabricated to permit adequate adjustment after erection while still supporting the load. Exception to this maybe made in cases where hangers are to be used for the support of piping requiring exact grades, for which they may be fabricated as rigid hangers.

F. Screw adjustments shall be fabricated so that all threaded members conform to American Standard B1.1 coarse-thread series Class 2 fit. Turnbuckles and adjusting nuts shall have the full length of thread in service. Means shall be provided for determining that full length of thread is in service. All screw or equivalent adjustments shall be provided with suitable locking features.

G. Supports shall be spaced so as to prevent excessive sag, bending, and shear stresses in the piping, with special consideration given to those piping sections where flanges, valves, etc., impose concentrated loads. Where calculations are not made, suggested maximum spacing of hangers or supports for carbon steel piping operating at 750 degrees Fahrenheit and lower are given in this part. Where greater distance between supports, concentrated loads, higher temperatures, or vibration considerations are involved, special consideration should be given to effects of bending and shear stresses. See also part 5230.1060, subpart 5, item E.

Subp. 7. Dimensional limitations. The following dimensional limitations apply:

A. Straps. Straps shall be limited to the minimum dimensions of one-eighth inch thickness by one inch width for use in locations protected from the weather. The minimum strap thickness for locations exposed to the weather shall be one-fourth inch. As exceptions to this, where straps are to be used for supporting pipe of one inch nominal size or smaller, the minimum strap dimensions shall be 1/16 inch thickness by three-fourths inch width in locations protected from the weather, and one-eighth inch thickness in locations exposed to the weather.

B. Hanger rods. The maximum load carried by a hanger rod used for the support of piping shall be based on the allowable stress of the material as specified in Par. 607, except that in no case shall hanger rods less than three-eighths inch diameter be used for supporting pipe of two inch nominal size and smaller or less than one-half inch diameter rod for supporting pipe 2-1/2 inches nominal size and larger. Safe loads for all threaded hanger rods shall be based on the root area of the threads. When the temperature of any part of a hanger rod does not exceed 450 degrees Fahrenheit and hanger rod material conforms to ASTM Specification A 107, such rods may be used for support of loads not in excess of those given in this part. Where rods are exposed to the weather or other corrosive elements, they shall be protected as stated in subpart 5 or fabricated from materials as described in subpart 3, according to the conditions. The minimum rod sizes for ferrous materials for these corrosive conditions shall be given for the noncorrosive condition. For nonferrous materials the minimum rod area for corrosive conditions shall be increased by the ratio of allowable stresses of steel to allowable stress of the nonferrous material used.

C. Load carrying capacities of threaded, hot, rolled, steel rod to ASTM Spec. A-107.

Nominal Rod Diameter	Root Area Thread	Maximum Safe Load, Pounds, 450 degrees Fahrenheit
3/8	0.068	610
1/2	0.126	1,130
5/8	0.202	1,810
3/4	0.302	2,710
7/8	0.419	3,370
1	0.552	4,960
1-1/8	0.693	6,230
1-1/4	0.889	8,000
1-3/8	1.053	9,470
1-1/2	1.293	11,630

D. Chain. Chain used for hangers shall be limited to stock having a minimum diameter of 3/16 inch or equivalent area for supporting pipe of two inches nominal size or smaller. For supporting pipe of 2-1/2 inches nominal size and larger, chain used in the fabrication of hangers which are to be located in places protected from the weather shall be limited to stock having a minimum diameter of three-eighths inch or equivalent area. Rods for chain hangers shall be fabricated in accordance with subpart 7. Where such composite chain hangers are to be exposed to the weather or other corrosive elements, castings, and chain stock as well as the rods and all parts shall be fabricated, where applicable, from materials with the same minimum requirements as described in subpart 4 or protected as stated in subpart 5 according to conditions. The minimum sizes of chain stock for these corrosive conditions shall be as given above for the noncorrosive condition.

E. Bolted clamps. Bolted clamps formed from plate or rectangular sections used in connection with rod or chain hangers shall have minimum thickness of 3/16 inch. Bolts used with these clamps shall have a minimum diameter of three-eighths inch. All parts of the bolted clamps, including bolts, shall conform with the requirements of part 5230.1030, subpart 3; and subpart 9 of this part.

F. Welded attachments. Lugs, plates, angle clips, etc., used as part of an assembly for the support or guiding of pipe may be welded directly to the pipe provided the material is of good weldable quality and the design is adequate for the load. The design of hanger lugs for attachment to piping for high temperature service shall be such as to provide for differential expansion between the pipe wall and the attached lug. Welds shall be proportioned so that the shear stresses shall not exceed 0.8 times the S values of the code under which piping is designed for

the respective operating temperatures of the piping. If materials for attachments have different stress values than the pipe the lower stress value of the two should be used. All such attachment welds shall be preheated as required for the pipe. Postheating is required for carbon steel attachments to carbon steel pipe if the attachment welds exceed three-fourths inch throat dimension. Preheating and postheating of attachments to alloy pipe shall be in accordance with the procedure qualifications. Welding shall be done by operators and procedures qualified in accordance with the rules of part 5230.1070.

Subp. 8. Allowable stresses. The allowable stress for the base material of all parts of supporting assemblies shall not exceed the appropriate S value taken from the allowable stress tables in the applicable section of the code at the maximum operating temperature of the part in question for seamless material of the same nominal chemical analysis and with tensile and yield strengths not higher than the materials used.

For other carbon steel materials used below 650 degrees Fahrenheit the allowable stress shall be no more than 12,000 psi.

The allowable stress shall be reduced 25 percent for threaded members based on the area, at the root of threads and for welds in support assemblies or for attachments to piping.

An increase in allowable stress of 20 percent shall be allowed for short time overloading conditions.

For requirements pertaining to springs see subpart 6, items A and B.

Subp. 9. Loading. The required strength of all supporting equipment, except springs, shall be based on the weight of the pipe, the weight of medium transported, or the medium used for testing, whichever is heavier, and the weight of the insulating cover, if used.

Weight calculations for springs should be based upon the normal operating conditions of the piping. They should not include the weight of the hydrostatic test fluid. Springs shall be designed for unit fiber stresses that will not be exceeded during any condition of loading or test; otherwise suitable travel stops to prevent overstressing the spring shall be provided.

Exceptions may be made in the case of supporting equipment for large gas or air piping, exhaust steam relief, or safety valve relief piping, but only under conditions where the possibility of any of these lines becoming full of water or other liquid is very remote.

Wind pressure shall be included in the calculations for the strength and structural features of the supports for exterior piping. Snow and ice loads shall also be considered in localities where such conditions occur.

Subp. 10. Supports permitting pipe movement. Hangers and supporting equipment shall be fabricated and assembled to permit the free movement of piping as caused by thermal expansion and contraction or by other causes. This should be accomplished by the use of long rod hangers, spring hangers, chains, hangers, or supports fitted with rollers, machined blocks, elliptical, or circular rings of larger diameter than the pipe causing contact only at the bottom, trolley hangers, or equivalent. Rolling supports shall be accurately made, properly guided, and shall roll freely. Hanger rods shall be provided with welded or forged eyes, pivoting clamps, T heads with suitable sockets, or equivalent. In all cases allowance shall be made for rod clearance to permit swinging without setting up severe bending action in the rods. When pipe is covered by insulation, a suitable metal shield properly constructed and secured to the covered pipe should be used to protect the covering at points where the pipe is supported on movable rolling supports or in larger diameter rings, except that where the nature of the material permits, the pipe may rest directly on the insulation without metallic supports.

Subp. 11. Spring hangers, compensating hangers, sway bracings, and vibration dampeners. The following limitations apply:

A. The design fabrication and installation of this equipment shall not constrain the piping when expansion or contraction occurs, to such an extent as to cause excessive transfer of loads from support to piping or from support to support. In any case, supports, whether of the rigid or spring types, shall be capable of taking the entire piping load imposed by weight transfer, by failure of springs in spring supports, or added load resulting from testing during erection.

B. All springs shall be provided with means to prevent misalignment, buckling, eccentric loading of the spring, and with stops to prevent excessive spring deflection that would be the cause of excessive spring stresses.

C. It is recommended that all hangers employing springs be provided with means to indicate at all times the proper position of the spring with respect to the hot and cold position of the piping system, except where they are used either to cushion against shock or where the operating temperature of the piping system does not exceed 250 degrees Fahrenheit.

D. Each spring or compensating-type hanger or support shall be designed to exert a supporting force equal to the load at point of attachment to the pipe, as determined by weight balance calculations. On high temperature and critical lines where changes in thermal conditions in the piping cause a change in supporting effect of such hanger or support, the excess or deficiency of support shall be included in the determination of total stresses in the piping.

E. On high temperature and critical piping at locations subject to appreciable movement with thermal changes, the use of spring or compensating type hangers or supports, designed to provide a substantially uniform supporting force equal to the load throughout the range of travel, is recommended. The piping should also be supported in a manner to keep thrust and moments on equipment at a minimum.

F. On high temperature and critical piping when conditions of item E do not apply, either compensated type hangers or supports, or spring hangers, which are designed for a maximum variation in supporting effect of 25 percent for the total vertical travel between the hot and cold positions, may be used.

G. When necessary to prevent abnormal movement or vibration in pipelines, sway braces or vibration dampeners shall be used. They shall be installed so as to cause minimum possible restraint to the normal thermal movements. The use of sway braces of the energy-absorbing or instant counter force acting type are recommended for control of undesirable pipeline movement. Rigid braces are also effective in controlling movement provided they do not restrict the flexibility of the piping or provided their effect is taken into account in the design of the piping flexibility.

Subp. 12. Counterweights. Counterweights when used instead of spring hangers shall be provided with stops to limit travel. Weights shall be positively secured with bolts or placed in suitable box compartments. The fabrication of chains, cables, hanger, and rocker arm details, or other devices used to apply the counterweight load to the piping, shall be subject to the requirements indicated herein under part 5230.1030, subparts 1 and 2.

Subp. 13. Anchors and guides. Anchors, guides, pivots, or restraints shall be fabricated and assembled in such a form as to secure the desired points of piping in relatively fixed positions. They shall permit the line to expand and contract freely in opposite directions away from the anchored or guided point, and shall be so arranged as to be structurally suitable to withstand the thrust, torsional forces, and load conditions of operation. Materials and fabrication shall be in accordance with the requirements of parts 5230.1030, subparts 1 and 3, and 5230.1040, subpart 8.

Where corrugated or slip-style expansion joints are used, anchors shall be provided to force the expansion movement into the joint, with such anchors designed to withstand a force equal to the force as recorded by the manufacturer

for the operating pressure at which the joint is to be used. If the manufacturer does not supply this force figure, the anchor shall be designed to withstand a force equal to the sum of the product of the maximum internal area times the maximum working pressure in the line plus an allowance to overcome friction. Where friction factor is not known, the anchor shall be designed to withstand a force equal to twice the product of the maximum internal area times the maximum pressure in the line. In all cases the allowable stresses in the line shall be in accordance with part 5230.1040, subpart 8.

All lines containing expansion joints shall be properly guided to direct movement into the expansion joint.

Statutory Authority: *MS s 326.46*

5230.1050 FABRICATION OF PIPE JOINTS OTHER THAN WELDED.

Subpart 1. Classification. The following classifications apply:

A. Ferrous pipe. Specific requirements are outlined herein for threaded joints and the more common type of flanged joints. However, this code permits the use of special joints such as rubber or flexible rings held tight by pressure and properly retained; sleeve or gland type, hub and spigot, screwed, or flanged union connections, flared and compression type joints, and any other connection, the joints and materials of which are suitable for the service conditions encountered as required by other sections of the code.

B. Nonferrous pipe. Valves, fittings, and flanges may be attached to non-ferrous pipe and tubing by the following methods, and may be used at pressures and temperatures permitted by this code for the pipe or tubing unless otherwise specified: by threading when the pipe is made to standard pipe size dimensions, by flanged or lapped connection, by flared or compression type joints where such joints are suitable for the pressure encountered, or by soldered or brazed socket sleeve type joints.

Joints of the socket sleeve type, in accordance with American Standard for Cast Brass Solder-Joint Fittings, ASA B16.18, and American Standard for Wrought Copper and Wrought Bronze Solder-Joint Fittings, ASA B16.22, may be used for pressure and temperature ratings therein specified.

Other socket sleeve type joints using a brazing solder melting at or above 1,100 degrees Fahrenheit, where the brazed junction between pipe and sleeve extend full depth of socket, are acceptable. Fillet brazed joints are not acceptable.

Subp. 2. Threaded joints. Screw threads shall conform to American Standard for Taper Pipe Threads, ASA B2.1, or to API Standards 5L for line pipe threads and 5A for casing threads.

Subp. 3. Flange requirements. The following requirements apply:

A. Flanges cast or forged integral with pipe, fittings, or valves shall be permitted in sizes and for the maximum service ratings covered by the American Standards or as defined in other sections of this code.

B. Screwed companion flanges shall be permitted in sizes and for maximum service ratings covered by American Standards or as defined in other sections of this code. The requirements for threaded joints in part 5230.1050, subpart 3 apply to this type of flange.

C. Lapped flanges shall be permitted in sizes and pressure standards established in the American Standard for Steel Pipe Flanges and Flanged Fittings, ASA B16.5, or as defined in other sections of this code.

D. Slip-on welding flanges shall be permitted in sizes and pressure standards established in the American Standard for Steel Pipe Flanges and Flanged Fittings, ASA B16.5, or as defined in other sections of this code. For methods of welding, see part 5230.1230, figure 6a-b. For service below 150 psig, slip-on flanges fabricated from flat plates may be substituted for hubbed slip-on flanges, provided the inherent weakness of locating the weld at the region of highest flange

stress is taken into account in establishing the service temperature and pressure conditions. For service 150 psig and above, slip-on flanges fabricated from flat plate may be used provided the thickness of the flange is equivalent to the flange thickness of the next higher pressure class for the same size (ASA B16.5). The method of attachment shall be as shown in part 5230.1050, subpart 3, figure 6 a-b.

E. Welding neck flanges shall be permitted in sizes and pressure standards established in the American Standard for Steel Pipe Flanges and Flanged Fittings, ASA B16.5, or as defined in other sections of this code. The bore of the flange shall correspond to the inside diameter of the pipe used. The welding shall comply with part 5230.1070 on welding of pipe joints.

F. Socket-welding flanges shall be permitted in sizes and pressure established in the American Standard for Steel Pipe Flanges and Flanged Fittings, ASA B16.5, or as defined in other sections of this code.

G. Steel flanges, provided with grooves into which the pipe is expanded, shall be permitted in sizes and for maximum service ratings outlined for screwed companion flanges in part 5230.1050, subpart 3.

Subp. 4. Flange facing, facing finish, and flange bolting. The following limitations apply:

A. The flanges described in the following standard are regularly faced as shown below:

Rating	Material	Dimensional Standard	Facing
25	Cast iron	ASA B16b2	Plain (flat)
125	Cast iron	ASA B16.1	Plain (flat)
250	Cast iron	ASA B16b	1/16 raised
150 & 300	Brass or bronze	ASA B16.24	Plain (flat)
150	Corrosion resistant	MSS SP-42	Plain (flat)
150 & 300	Steel	ASA B16.5	1/16 raised
400, 600, 900, 1,500 & 2,500	Steel	ASA B16.5	1/4 raised

B. Other flange facings as shown in American Standard for Steel Pipe Flanges and Flanged Fittings, ASA B16.5, are permitted. Such facings shall be subject to pressure temperature limitations shown in ASA B16.5 or as defined in other sections of this code.

C. The finish of facings shall be in accordance with MSS Standard Finishes for Contact Faces of Connecting-End Flanges of Valves and Fittings, MSS SP-6.

D. Twenty-five psi and class 125 cast-iron integral or screwed companion flanges may be used with a full face gasket or with a ring gasket extending to the inner edge of the bolt holes. When using a full-face gasket, the bolting may be of heat-treated carbon steel, ASTM A 261, or alloy steel, ASTM A 193. When using a ring gasket, the bolting shall be of carbon steel equivalent to ASTM A 307 Grade B without heat-treatment other than stress relief.

E. When bolting together two class 250 integral or screwed companion cast-iron flanges, having 1/16 inch raised faces, the bolting shall be of carbon steel equivalent to ASTM A 307 grade B, without heat-treatment other than stress relief.

F. 150 psi steel flanges may be bolted to cast-iron valves, fittings, or other parts, having either integral class 125 cast-iron flanges or screwed class 125 companion flanges. When such construction is used, the 1/16 inch raised face on the steel flange shall be removed. When bolting such flanges together using a ring gasket extending to the inner edge of the bolt holes, the bolting shall be of carbon steel equivalent to ASTM A 307 grade B, without heat treatment other than stress

relief. When bolting such flanges together using a full face gasket, the bolting may be heat treated carbon steel, ASTM A 261, or alloy steel, ASTM A 193.

G. 300 psi steel flanges may be bolted to cast-iron valves, fittings, or other parts having either integral class 250 cast-iron flanges or screwed class 250 cast-iron flanges or screwed 250 cast-iron companion flanges without any change in the raised faces on either flange. Where such construction is used, the bolting shall be of carbon steel equivalent to ASTM A 307 grade B, without heat treatment other than stress relief. Good practice indicates that the raised face on the steel flange should be removed, but also in this case, bolting shall be of carbon steel equivalent to ASTM A 307 grade B without heat-treatment other than stress relief.

Subp. 5. **Gaskets.** The following limitations apply:

A. Dimensions of nonmetallic gaskets are shown in American Standard for Nonmetallic Gaskets, ASA B16.21.

B. Paper, vegetable fiber, rubber, or rubber-inserted gaskets shall not be used for temperatures in excess of 250 degrees Fahrenheit.

C. Asbestos composition gaskets may be used as permitted in the American Standard for Steel Pipe Flanges and Flanged Fittings, ASA B16.5. This type of gasket shall not be used on lines carrying oil or other fluids above their spontaneous ignition temperatures unless specifically approved in the individual sections of this code.

D. The use of metal or metal asbestos gaskets, is not limited as to pressure provided that the gasket material is suitable for the service temperature. These types of gaskets are recommended for use with the small male-and-female or the small tongue-and-groove facings. They may also be used with steel flanges having large male-and-female, large tongue-and-groove, or raised face.

E. Full face gaskets shall be used with all bronze flanges and are recommended for corrosion resistant steel flanges conforming to MSS SP-42, and may be used with 25 psi or class 125 cast iron flanges. Ring gaskets, with an outside diameter extending to the inside of the bolt holes, may be used with cast iron flanges or with plain or raised face steel flanges.

F. In order to secure higher unit compression on the gasket, gaskets of a width less than the full male face of the flange may be used with steel flanges with any of the following facings; raised face, large male and female; otherwise, widths of gaskets for large male and female joints are recommended to be equal to the width of the male face. Widths of gaskets for small male and female, or for all tongue-and-groove joints shall be equal to the width of the male face, or tongue. All gaskets shall have an inside diameter equal to, or larger than, the port opening.

G. Rings for ring joints shall be of dimensions and quality established in the American Standard for Ring-Joint Gaskets and Grooves for Steel Pipe Flanges and Flanged Fittings, ASA B16.20.

Statutory Authority: *MS s 326.46*

5230.1060 EXPANSION AND FLEXIBILITY.

Subpart 1. **Scope.** The provisions of this chapter are not applicable to gas, air, and oil cross-country transmission (underground) piping.

Subp. 2. **Preamble.** Piping systems are subject to a diversity of loadings creating stresses of different types and patterns, of which only the following more significant ones need generally be considered in piping stress analysis: pressure, internal or external; weight of pipe, fittings, and valves, containing fluid and insulation, and other external loadings such as wind; or thermal expansion of the line.

The first two loadings produce sustained stresses which are evaluated by conventional methods. The stresses due to thermal expansion on the other hand, if of sufficient initial magnitude will be relaxed as a result of local flow in the form

of yielding or in the form of creep. The stress reduction which has taken place will appear as a stress of reversed sign in the cold condition. This phenomenon is designated as self-springing of the line and is similar in effect to cold springing. This amount of such self-springing will depend on the magnitude of the initial hot stress and the temperature. Accordingly, while the hot stress tends to diminish with time, the sum of the hot and cold stresses during any one cycle will remain substantially constant. This sum is referred to as the stress range. The fact that the stress range is the determining factor leads to the selection of an allowable combined stress (range) in terms of the sum of the hot and cold S values.

Subp. 3. Adverse conditions. Where due to severe service conditions or special configurations, excessive local strains may occur under prolonged heating in materials of limited ductility, the effect of such conditions should be considered. For example, it is possible to have a pipe line configuration with the following adverse conditions:

A. one or more branches which are small in size compared with the majority of the piping;

B. a calculated high expansion stress level in the small size branch with the remainder of the piping at relatively low expansion stress levels; or

C. a relatively small elastic deformation in the small size branch coincident with the high expansion stress level; and a relatively large amount of absorbed expansion stored in the low stressed areas of the system to act as an elastic follow up spring thereby maintaining elastic deformation on the small size, high expansion stressed area.

When all three of the above conditions exist, it is possible to produce an undesirable amount of creep in the small size, high expansion stressed area. Such undesirable creep could be avoided by a redesign of the piping or by judicious cold springing of the system. Until more is known about the fabrication and treatment of austenitic steels, it is recommended that the design of piping systems of such materials be approached with greater overall care as to general elimination of local stress raisers, inspection, material selection, fabrication quality, and erection. As a part of this approach the need for hot plastic flow can be minimized by careful cold springing.

Subp. 4. Cold springing. The beneficial effect of judicious cold springing in assisting the system to attain its most favorable condition sooner is recognized. Inasmuch as the life of a system under cyclic condition depends primarily on the stress range rather than the stress level at any one time, no credit for cold spring is warranted with regard to stresses. In calculating end thrusts and moments acting on equipment containing moving or removable parts with close clearances, the actual reactions at any one time rather than their range are significant and credit accordingly is allowed for cold spring in the calculations of thrusts and moments.

Subp. 5. Materials. The following limitations apply:

A. This chapter applies to all classes of materials permitted by the code.

B. The thermal expansion range shall be determined from item C the difference between the unit expansion shown for the maximum normal-operating metal temperature and that for the minimum normal-operating metal temperature. For hot lines, this may usually be taken as the erection temperature. For materials not included in this table, reference shall be made to authoritative source data, such as publication of the National Bureau of Standards.

C. Linear expansion of piping:

Constants per 100 feet

Formula:

Metal

$E =$ expansion in inches per 100 feet of pipe

Steel .00804

Wrought Iron .00816

$F =$ starting temperature

MINNESOTA RULES 1991

5155

PIPEFITTERS; POWER PIPING SYSTEMS 5230.1070

Cast Iron	.00780	T = final temperature
Copper and Brass	.01140	E = constant x (T - F)

D. General: Piping systems shall be designed to have sufficient flexibility to prevent thermal expansion from causing failure from over-stress of the piping material or anchors, leakage at joints, or detrimental distortion of connected equipment resulting from excessive thrusts and moments.

Flexibility shall be provided by changes of direction in the piping through the use of bends, loops, and offsets; or provisions shall be made to absorb thermal strains by expansion joints of the slip joint or bellows type.

If desirable, flexibility may be provided by creasing or corrugating portions or all of the pipe.

In this case, anchors or ties of sufficient strength and rigidity shall be installed to provide for end forces due to fluid pressure and other causes.

In order to modify the effect of expansion and contraction, runs of pipe may be cold sprung. Cold spring may be taken into account in the calculation of the reactions as shown, provided an effective method of obtaining the designed cold spring is specified and used.

To find temperature of saturated steam, take square root of gauge pressure times 14 plus 198.

Example: Find temperature of 100# psi saturated steam.

$$100^2 = 10 \times 14 = 140 \text{ plus } 198 = 338 \text{ degrees Fahrenheit.}$$

$$100\# \text{ Saturated Steam} = 338 \text{ degrees Fahrenheit.}$$

E. Supports: Pipe supports and restraints not expressly considered in flexibility calculations shall be designed to minimize interference with the thermal expansion of the line. The design and spacing of supports shall be checked to assure that the sum of the longitudinal stresses due to weight, pressure, and other sustained external loading does not exceed allowable stress.

F. Elastic constants and coefficients of thermal expansion. The coefficients of thermal expansion and values of linear expansion per 100 feet are given in item C.

Statutory Authority: *MS s 326.46*

5230.1070 WELDING OF PIPE JOINTS.

Subpart 1. **Scope.** This part concerns the welding of pipe joints in both wrought and cast ferrous materials, and more specifically covers butt joints in pipe, valves, flanges and fittings, and fillet joints in pipe branches, slip-on flanges, socket weld fittings, etc., as applied in pipe lines and connections to apparatus or equipment. The requirements of this code are applicable except where the welding of such joints are covered by other codes or state regulatory bodies, such as the Power Boiler and Unfired Pressure Vessel sections of the ASME Boiler and Pressure Vessel Code. The general provisions of this part are subject to accompanying code regulations as to pressure, temperature, and fluid carried.

This part applies to the manual application of shielded metal arc, inert gas metal arc, and gas welding processes, and to the automatic, semiautomatic, and machine welding application of the submerged arc and inert gas shielded arc processes. These rules may, however, be applied to other manual or machine welding processes in so far as the rules are applicable.

Standard qualifications for welding procedures, welders, and welding operators made in accordance with section IX of the ASME Boiler and Pressure Vessel Code will also qualify for such work under this code as outlined below.

Subp. 2. **Manufacturer's or contractor's responsibility.** Each manufacturer or contractor shall be responsible for the quality of the welding done by his organiza-

tion and shall, except as provided in item F, conduct tests not only of the welding procedure to determine its suitability to insure welds which will meet the required tests, but also of the welders to determine their ability to properly apply the procedure, as follows:

A. The welding procedure followed during the qualifying test shall be recorded in detail, and shall be accessible to the purchaser or his agent. This procedure shall be adhered to during subsequent construction. Recommended forms for recording the results of procedure qualification tests are given in part 5230.1110, subparts 1 and 2.

B. Qualification tests on ferrous materials shall be in accordance with the provisions of parts 5230.1090 and 5230.1100. Qualification tests may be in accordance with the provisions of part A, section IX, ASME Boiler and Pressure Vessel Code.

C. Welding qualification tests on nonferrous materials shall be in accordance with part B, Requirements for Nonferrous Materials, section IX, ASME Boiler and Pressure Vessel Code.

D. The employer shall assign an identification number, letter, or symbol to each welder which shall be used to identify the work of that welder.

E. The employer shall maintain a record of the welders employed by him, showing the date and result of tests and the identification mark assigned to each. These records shall be certified by the manufacturer and be accessible to the purchaser or his agent.

F. To avoid duplication of qualification tests of procedures or welders, the procedures or welders qualified as required above by one employer may, if suitable, be accepted by another employer on piping using the same or an equivalent procedure wherein the essential variables are within the limits established in parts 5230.1090, subpart 2, and 5230.1100, subpart 4. It is the contractors, fabricators, or purchasers prerogative to accept or reject qualification tests made by others. An employer accepting the qualification tests of welders by another employer shall clearly indicate in his record of such welders, the employer by whom the welders were qualified and the dates of such qualification; by so doing the employer accepts the responsibility for the welder's workmanship.

Subp. 3. Definitions. For convenience in reference, some of the more common terms relating to pipe welding are defined in "Standard Welding Terms and Their Definitions," American Welding Society A3.0.

Subp. 4. Material. All ferrous materials used in the fabrication of any welded pipe or piping assembly or attachments welded thereto, and covered by this code shall be of good weldable quality and conform to ASTM or API material specifications.

Subp. 5. Base metal preparation for welding. Butt welds: preparation of pipe ends shall be done preferably by machining and/or grinding, although oxygen or arc cutting is acceptable if the cut is reasonably smooth and true and all heavy oxide is thoroughly cleaned from the flame cut surfaces. Preheating may be required on certain alloy materials of the air hardening type in order to prevent surface checking or cracking adjacent to the torch-cut surface. The discoloration which may remain on the flame cut surface is not considered to be detrimental oxidation. End preparations are given in part 5230.1200, figure 3, as representing present recommended practice. For more detailed dimensional information, reference may be made to American Standard Steel Pipe Flanges and Flanged Fitting, ASA B16.5.

Surfaces for welding shall be cleaned and shall be free from paint, oil, rust, scale, or other objectionable material which may be detrimental to the weld.

The ends of pipe-to-pipe, pipe-to-fitting, and pipe-to-valve joints shall be aligned as accurately as is practical within the existing commercial tolerances on pipe diameters, pipe wall thickness, and out-of-roundness. Alignment should pro-

vide the most favorable conditions for the deposition of the root bead. This alignment must be preserved during welding. In smaller internal diameter shall be internally trimmed so that the adjoining internal diameters will result in approximately the same thickness as in part 5230.1210, figure 4. In no case, however, shall trimming of the inside diameter result in a wall thickness less than the minimum required for the service condition as prescribed in the applicable section of this code.

The root opening of the joint shall be as given in the manufacturer's procedure specification.

Backing rings may or may not be used. Where ferrous metal backing rings are used they shall be made from material of good weldable quality and shall not exceed .05 percent sulfur. The material of the backing ring should be compatible with the chemical composition of the pipe, valve, fitting, or flange with which it is to be used and preferably be of the same composition. When two abutting surfaces are welded to a third member used as a backing ring and one or two of the three members are ferritic and the other member or members are of an austenitic grade of material, a procedure qualification shall be required. Backing rings may be of the continuous machined or split band type. Some acceptable types are shown in part 5230.1220, figure 5.

If pipe ends are bored for accurate fitting machined rings, such boring shall not reduce the pipe wall below the minimum required thickness. In some instances it may be necessary to deposit weld metal on the inside diameter of the pipe or welding fitting to provide sufficient material for machining to insure satisfactory seating of machined backing rings.

If the pipe ends are of the upset type they may be bored to allow for a completely recessed backing ring, provided in any case the remaining net section of the finished joint is not less than the minimum required thickness.

Backing rings of nonferrous or nonmetallic materials may be permitted provided they have no effect on the mechanical, physical, and chemical properties of the weld. The satisfactory use of such materials shall be determined by procedure qualification.

Fillet welds: slip-on flanges, socket weld fittings, and valves shall be prepared in accordance with applicable parts of this subpart and reference to parts 5230.1230, figure 6, and 5230.1240, figure 7.

A one-eighth inch vent hole may be desirable in the hub of any slip-on flange which is subject to being front and back welded and which is also subject to furnace stress relieving.

Subp. 6. Welding procedure. Butt welds: butt joints may be of the single vee, double vee, or other suitable type of groove with or without backing rings. When backing rings are used, typical joint designs as in subpart 5 are recommended. When backing rings are used and the nominal pipe wall thickness and service conditions are such that it is not considered necessary or practical to machine the inside of the pipe, the joint design shown in part 5230.1220, figure 5 is recommended. When backing rings are used and the nominal pipe wall thickness and service conditions are such that it is considered necessary to machine the inside of the pipe, the joint designs shown in part 5230.1220, figure 5 (b) or (c) or applicable combinations of these joint design details are recommended.

If tack welds are used, they shall either be made by a qualified welder and the same procedure as the completed weld, or be removed during the welding operation. When heavy assemblies are transferred from the location of fit-up to the location of welding, extreme care should be exercised to see that all joints have been adequately tack welded or welded to prevent the cracking of these welds, or the distortion of the assembly during such transfer. Piping which is to be welded in place shall be properly aligned and adequately supported during tack welding and subsequent welding in order to avoid the possible cracking of tack welds and initial beads.

The welding procedure shall be such as to assure substantially full root penetration and thorough fusion of the deposited metal with the base metal. Assurance of the specified degree of penetration actually obtained in production welds, is dependent upon the degree and type of examination made. The degree of examination and basis of rejection shall be a matter of prior agreement between the fabricator or contractor and purchaser.

The external surface of butt welds shall be free from undercuts greater than 1/32 inch in depth, overlaps or abrupt ridges or valleys and shall merge smoothly into the pipe surface at the weld toe. The thickness of weld reinforcement shall not exceed 3/32 inch for pipe thickness up through one-half inch, one-eighth inch for pipe thickness over one-half inch through one inch, or one-eighth inch times weld width for pipe thickness over one inch.

Fillet welds may be convex to concave. The size of a fillet weld is determined by the leg length of the largest inscribed right isosceles triangle.

Seal welding of threaded joints is permitted provided the external threads are entirely covered by the seal weld. Seal welds shall not exceed three-eighths inch throat dimension and shall not be considered as contributing to the strength of joints. Seal welding shall be done by qualified welders.

Subp. 7. Preheating. Preheating shall be required as stipulated for the various materials listed in the various "P" groups, as follows:

A. Preheating of materials listed under "P" numbers 1 and 2 is not mandatory but under certain conditions is recommended. Under field conditions or otherwise where the ambient temperature is less than 32 degrees Fahrenheit, local preheating to a hand-hot condition is suggested for all materials listed in "P" numbers 1 and 2. Experience has indicated that preheating to 250 degrees Fahrenheit is advisable (regardless of ambient temperature) when welding those materials listed under "P" number 1 which have minimum tensile properties of 70,000 psi or higher.

B. Preheating to 300 degrees Fahrenheit minimum shall be required when welding all materials listed under "P" number 3.

C. Preheating to 375 degrees Fahrenheit minimum shall be required when welding all materials listed under "P" number 4.

D. Preheating to a temperature of 450 degrees Fahrenheit minimum shall be required when welding material listed under "P" numbers 5 and 6.

E. Preheating of material listed under "P" number 7 shall be a matter of agreement between the manufacturer or contractor and the purchaser.

F. Preheating of the austenitic stainless grades of material listed under "P" number 8 is optional and is not a requirement of this code.

G. When welding dissimilar materials having different preheat requirements, the preheating temperature shall be that established in the procedure specification.

Preheating may be accomplished by any suitable method provided that it is uniform and that the temperature is maintained above the minimum during the actual welding operations.

The preheating temperature shall be checked by the use of temperature indicating crayons, thermocouple pyrometers, or any other suitable method to assure that the required preheat temperature is obtained prior to and maintained during the welding operation.

Subp. 8. Stress relieving schedule. Unless otherwise provided in other sections of this code, the following stress relieving schedule will apply:

A. Welded joints in carbon steel materials as listed under "P" number 1, shall be stress relieved when the pipe wall thickness is three-fourths inch or greater. In unreinforced and reinforced branch connections, the thickness of the run shall govern. When flanges are attached by fillet welds, the thickness of the pipe shall govern.

MINNESOTA RULES 1991

5159

PIPEFITTERS; POWER PIPING SYSTEMS 5230.1070

B. Welded joints in wrought iron pipe as listed under "P" number 2 shall require stress relieving only as a matter of agreement between the purchaser and the fabricator.

C. Welded joints in carbon molybdenum steel material listed under "P" number 3, shall be stress relieved when the pipe wall thickness is one-half inch or greater.

D. Welded joints in all other alloy materials listed under "P" number 3, and all materials listed under "P" numbers 4, 5, and 6, shall be stress relieved without regard to wall thickness.

E. Stress relieving or other post weld heat treatment of the high alloy ferritic materials listed under "P" number 7 and the austenitic stainless grades of material listed under "P" number 8 is not a requirement of this code, but may be performed as a matter of agreement between the purchaser and the fabricator. If stress relieving or heat treatment is agreed upon, it should be compatible with the analysis of both the base metal and the weld metal and should be determined as most suitable for the particular service application.

F. In welds between dissimilar ferritic materials, if either material requires stress relieving, the joint shall require stress relieving.

G. In welds between austenitic and ferritic materials, stress relieving or other post weld heat treatment of the welded joint is optional. Stress relieving or heat treatment, if used, shall be a matter of agreement between the contractor and the purchaser. Due to differences in the coefficient of thermal expansion existing between dissimilar materials, careful consideration should be given to the selection of a heat treatment, if any, that will be beneficial to the welded joint.

Subp. 9. **Stress relieving temperature.** Stress relieving should not be confused with other post weld heat treatments which, if required, shall be a matter of agreement between the manufacturer and the purchaser. Such post weld heat treatments may or may not obviate the necessity of stress relieving depending upon the maximum temperature attained in the post weld heat treatment and the rate of cooling from the temperature.

Stress relieving shall be performed at a temperature of 1,100 degrees Fahrenheit or over for carbon steels, and 1,200 degrees Fahrenheit or over for ferritic alloy steels. The exact temperature range shall be established in the procedure specification.

When stress relieving a joint between dissimilar ferritic materials or between austenitic and ferritic materials, having different stress relieving requirements, the temperature used shall be that established in the procedure specification.

The parts heated shall be brought uniformly to the required temperature and held at that temperature for a period of time proportioned on the basis of at least one hour per inch of pipe wall thickness, but in no case less than one-half hour, and shall be allowed to cool slowly and uniformly.

Subp. 10. **Methods of stress relieving.** Methods of stress relieving are:

A. Heating the complete structure as a unit.

B. Heating a complete section containing the weld or welds to be stress relieved before attachment to other sections of work.

C. Heating a part of the work by heating slowly a circumferential band containing the weld at the center. The width of the band which is heated to the required temperature shall be twice that of the weld reinforcement but need not exceed the width of the weld reinforcement by more than two inches. Extreme care should be used to obtain a uniform temperature around the entire circumference of the pipe. The temperature shall diminish gradually outward from the ends of this band.

D. Branches or other welded attachments for which stress relief is required, should preferably be furnace stress relieved. Where furnace stress relief

is impractical, local stress relief may be accomplished by heating a circumferential band around the pipe on which the branch or attachment is welded with the branch or attachment at the middle of the heated band. The width of the band shall be at least two inches greater than the diameter of the weld joining the branch or attachment to the header. The entire band shall be brought up to the temperature and held for the time specified.

Subp. 11. **Equipment for local stress relieving.** Stress relieving may be accomplished by electric induction heating, electric resistance heating, fuel fired ring-burners, fuel fired torch, or other suitable means of heating provided a uniform temperature is obtained and maintained during the stress relieving cycle.

Subp. 12. **Checking temperature.** The stress relieving temperature shall be checked by the use of thermocouple pyrometers or other suitable equipment to be assured that the proper stress relieving cycle has been accomplished.

Subp. 13. **Identification.** After completing a welded joint, the welder shall stamp or otherwise identify it as his work with his assigned number, letter, or symbol.

Subp. 14. **Hydrostatic tests.** Piping and associated equipment fabricated with welded joints shall be capable of withstanding hydrostatic tests as specified in the section of this code covering the class of service for which the pipe is to be used.

In all cases, the required test pressure shall be maintained a sufficient length of time to enable an inspection to be made of all joints and connections.

Subp. 15. **Inspection of welded joints.** Inspection of welded joints:

A. The acceptability of all types of production welds, whether or not complete or random radiography, magnetic particle, fluid penetrant, sectioning, etc., are specified, shall also be judged on the basis of a careful visual examination and/or shop or field hydrostatic test. Injurious defects shall be removed and repaired in accordance with items C and D.

B. When required in the specification or contract, or by agreement between the purchaser and the manufacturer or contractor, the quality of butt welds shall be checked, as follows:

When random radiographic examination, sectioning, or a combination of both, are specified, welded butt joints shall conform to ASME Unfired Pressure Vessel Code, section VIII, par. UW-52, except that unfusion attendant to root misalignment as permitted in subpart 5 shall be considered acceptable provided that such does not encroach on the minimum wall thickness. Furthermore, penetration shall be complete to the inside diameter of the pipe which has the greater inside diameter of the two pieces being joined.

When full radiographic examination is specified, welded butt joints shall conform to the ASME Unfired Pressure Vessel Code, section VIII, par. UW-51.

C. All defects in welds requiring repair, shall be removed by flame or arc gouging, grinding, chipping, and/or machining. All repair welds shall be made using the same, or other qualified welding procedures as that used in making the original welds, including preheating and stress relieving if originally required.

D. All repair welds shall meet the requirements of subpart 2 and shall be acceptable to the purchaser or his agent.

Subp. 16. **Qualification of procedures and welders.** The qualification of welding procedures, welders, and welding operators for welded joints of pipe shall be in accordance with parts 5230.1090 and 5230.1100. Qualification tests may also be made in accordance with the provisions of part A, section IX, ASME Boiler and Pressure Vessel Code.

Statutory Authority: *MS s 326.46*

5230.1080 STANDARD QUALIFICATION FOR WELDING PROCEDURES, WELDERS, AND WELDING OPERATORS.

Subpart 1. **General requirements.** Specific reference to the following material is made in part 5230.1070. Reference to this chapter in general, and to part 5230.1070, subpart 2 in particular, should be made before proceeding further in Appendix A of the ANSI code. It is assumed that the manufacturer or contractor has an organization familiar with the various welding codes and capable of designing, engineering, and supervising welded construction.

Each manufacturer or contractor is responsible for the welding done by his organization, and shall conduct the tests required in this section to qualify the welding procedures he uses in the construction of the weldments built under this code and the performance of welders and welding operators as defined in part 5230.1100 who apply these procedures, and shall maintain records thereof.

Subp. 2. **Scope.** The following rules apply to the qualification of welding procedures and welder performance for all types of manual, semiautomatic and automatic arc and gas welding processes permitted in other sections of the code. These rules may also be applied in so far as they are applicable to other manual or machine welding processes.

Subp. 3. **Definitions.** Some of the more common terms relating to welding are defined in the American National Standard Code for Pressure Piping, Power Piping, published by ASME, 1983 edition, as amended. These are in substantial agreement with the definitions of the American Welding Society, A 3.0 given in "Standard Welding Terms and their Definitions".

Subp. 4. **Weld orientation.** The orientations of pipe welds with respect to horizontal and vertical planes of reference are classified in accordance with part 5230.1250, figure 8 into four positions. These are flat, horizontal, vertical, and overhead.

Subp. 5. **Welding positions for qualification tests.** Welding positions for qualification tests:

A. Test welds for both procedure qualification and performance qualification shall be made on groove welds in pipe in one or more of the specified basic qualification test positions shown in part 5230.1260, figure 9. An angular tolerance of ± 15 degrees from the specified horizontal and vertical planes shall be allowed in making the test welds.

B. Both procedure and performance qualifications on groove welds in pipe in a given position, shall also qualify for groove welds in plate and fillet welds in pipe and plate for equivalent welding positions as shown in part 5230.1260, figure 9.

C. The basic qualification test positions are, as follows:

(1) pipe, horizontal rolled; weld, flat position. Pipe with its axis in the horizontal plane and rolled during welding so that the weld metal is deposited from the top and within ± 15 degrees from the vertical plane;

(2) pipe, vertical fixed; weld, horizontal position. Pipe with its axis in the vertical position and the weld with its axis in the horizontal plane;

(3) pipe, horizontal fixed; weld, flat, vertical, and overhead positions. Pipe with its axis in the horizontal plane and the welding groove in the vertical plane. Welding shall be done without rotating the pipe so that weld metal is deposited from the flat, vertical, and overhead positions.

D. Qualification in test position covered in item C, subitem (1) qualifies for that position only. Test positions covered in item C, subitem (2) or (3) shall qualify for the respective test positions and also for test position covered in item C, subitem (1).

Qualification in test position covered in both item C, subitems (2) and (3) are required for qualification in all weld positions, regardless of orientation of weld or pipe axis.

E. In cases when production welding is to be done in one particular position outside of that defined in item C, subitem (1) both procedure and welder qualification may be made for that position, with the limitation that procedure and welder qualification shall be varied only for the actual special position tested. An angular tolerance of ± 10 degrees shall apply.

Subp. 6. **Types of test specimens.** Test specimens for making qualification tests are two types; reduced-section tension specimens and guided-bend specimens. The reduced-section tension test is used to determine the tensile strength of the weld joint in procedure qualification tests. The dimensions and preparation of the test specimen shall conform to the requirements. The alternative 0.505 in. specimen may be used for material three-fourths inch and over in thickness. The guided-bend test is used to check for degree of soundness and ductility of the weld in both procedure and performance qualification tests. Guided-bend test specimens are of three kinds, as follows:

A. Side-bend test specimens that conform to the requirements shall be used in making guided-bend tests of welds that are over three-fourths inch in thickness and may be used in making guided-bend tests of welds that are over three-eighths inch in thickness.

B. Face-bend and root-bend test specimens that conform to the requirements shall be used in making guided-bend tests of welds that are 1/16 inch to three-eighths inch in thickness and may be used in making guided-bend tests of welds that are up to three-fourths inch in thickness. The face bend specimen shall be bent with the face of the weld in tension, and the root bend specimen shall be bent with the root of the weld in tension.

Subp. 7. **Reduced section tension tests.** The reduced-section tension test specimens shall be ruptured under tensile load. The tensile strength shall be computed by dividing the maximum load by the product of the least width and corresponding thickness of the specimen as measured before load is applied.

The reduced-section tension test specimen shall have a tensile strength that is not less than the minimum of the specified tensile strength of the base material or of the weaker of the two if materials of different specified minimum tensile strengths are used. If the specimen breaks in the base metal outside of the weld or fusion line, the test shall be accepted as meeting the requirements provided the strength is not more than five percent below the specified minimum tensile strength of the base metal.

Subp. 8. **Guided-bend test.** Side-bend, face-bend, and root-bend specimens shall be bent in a test-jig that has been approved by the Division of Pipefitting Standards. The specimen shall be placed on the die of the test-jig with the weld at mid-span. The side of the specimen turned toward the gap of the jig shall be the face for face-bend specimens, the root for root-bend specimens, and the side with the greater defects, if any, for side-bend specimens. The specimen shall be forced into the die by applying load on the plunger until the curvature of the specimen is such that a 1/32 inch diameter wire cannot be inserted between the die and the specimen.

Guided-bend specimens shall have no cracks or other open defects exceeding one-eighth inch measured in any direction on the convex surface of specimen after bending except that cracks occurring on the corners of the specimen during testing shall not be considered, unless there is definite evidence that they result from slag inclusions or other internal defects.

Statutory Authority: *MS s 326.46*

History: *14 SR 1877*

5230.1090 PROCEDURE QUALIFICATION.

Subpart 1. **General requirements.** The procedure of welding to be followed in construction shall be established and recorded in detail by the manufacturer

MINNESOTA RULES 1991

5163

PIPEFITTERS; POWER PIPING SYSTEMS 5230.1090

or contractor as a procedure specification, and in the investigation to qualify this procedure, the procedure specification shall be followed. The results of the procedure qualification test shall likewise be recorded in detail. Recommended forms for the procedure specification and procedure qualification test results are given in part 5230.1110, subparts 1 and 2. It is not necessary that these exact forms be used, but the information contained therein should be set forth in any alternate form which is adopted.

Subp. 2. Essential variables. The welding procedure must be set up as a new procedure specification and must be completely requalified when any of the changes listed below are made in the procedure. Changes other than those given below may be made in a procedure without the necessity for requalification provided the procedure specification is revised to show these changes.

A. V-1 A change from one welding process to another welding process.

B. V-2 A change in the specification of either or both of the base metals to be welded from one P-number in Table 1 to another P-number. Joints involving two base metals of different P-numbers shall be qualified even where procedure qualification tests on each of the two base metals welded to itself have previously been made.

C. V-3 A change in filler metal analysis or type shall require requalification under the following conditions:

(1) a-1 for metal arc-welding with covered electrodes a change from one F-number to any other F-number;

(2) a-2 for metal arc welding with covered electrodes a change in the chemical composition of the weld deposit from one A-number to any other A-number;

(3) b-1 for gas welding a change from a GAXX to a GBXX type of filler metal and vice versa;

(4) b-2 for gas welding a change from silicon-killed to an aluminum-killed type of filler metal and vice versa;

(5) b-3 for gas welding a change in weld metal composition from one A-number to any other A-number;

(6) c-1 for inert-gas consumable electrode metal arc-welding a change in weld metal composition from one A-number to any other A-number;

(7) c-2 for inert-gas nonconsumable electrode metal arc welding a change in weld metal composition from one A-number to any other A-number;

(8) d-1 for submerged arc welding a change from a filler metal containing 1.75 to 2.25 percent manganese to a filler metal containing less than 1.00 percent manganese or vice versa shall require requalification (the presence or absence of one-half percent molybdenum in the filler metal analysis shall not require requalification);

(9) d-2 for submerged arc-welding a change in filler metal analysis from one A-number to any other A-number;

(10) e-1 for any other welding process a change in the composition of the deposited weld metal from one A-number to any other A-number;

(11) V-4 in submerged arc welding, a change in the nominal composition or type of flux used (requalification is not required for a change in flux particle size);

(12) V-5 the addition of other welding positions than those already qualified (see part 5230.1080, subpart 5);

(13) V-6 a change in the heat treating temperature and time cycle range. The time may vary with the thickness of a specific material without requiring requalification.

(14) V-7 in metal arc-welding, the omission of the backing ring in welding single-welded butt joints; and in gas-welding, the addition of the backing ring in welding single-welded butt joints;

(15) V-8 in semiautomatic or automatic welding, a change from multiple pass per side to single pass per side;

(16) V-9 in semiautomatic or automatic welding, a change from single arc to multiple arc, or vice versa;

(17) V-10 in inert-gas arc-welding (consumable and nonconsumable electrode) a change from one type of inert-gas to another;

(18) V-11 for inert-gas arc-welding, a change from the consumable to nonconsumable electrode process or vice versa;

(19) V-12 For inert-gas nonconsumable electrode arc-welding a change in electrode (such as carbon electrode to tungsten electrode).

Subp. 3. Preparation of test joint. The base material, the filler metal, and the joint welding procedure shall comply with the procedure specification. The base materials shall consist of pipe having a minimum nominal diameter of five inches and a minimum wall thickness of three-eighths inch. Larger diameter and heavier wall pipe may be used, however, and will equally satisfy the procedure requirements. A smaller size pipe may be used such as job-size pipe, but in such cases the procedure shall be qualified only within the limitations. The test joint shall be welded using the type of welding groove specified in the procedure specification for use in construction.

Subp. 4. Type and number of test specimens. The type and number of test specimens that must be tested to qualify a procedure specification are given in part 5230.1270, subpart 1, figure 10, together with range of thickness that is qualified for use in construction by a given pipe wall thickness used in making the qualification. The test specimens shall be removed in the order shown in part 5230.1270, subparts 1 and 2. All tests shall meet the requirements prescribed in part 5230.1080, subparts 7 and 8.

Statutory Authority: *MS s 326.46*

5230.1100 PERFORMANCE QUALIFICATION.

Subpart 1. Purpose. These performance qualification tests are devised to determine the ability of welders and operators to make sound welds.

Subp. 2. Performance qualification of operators. The following tests are required for operators of machine welding equipment in which the rate of travel and the position of the welding-head with respect to the work are controlled mechanically except for minor adjustments for such factors as out-of-roundness, and lead-angle.

To assure that such an operator can carry out the provisions of the welding procedure, one 12-inch pipe joint, or equivalent length of welded joint shall be examined by radiography for each procedure under which he does welding. The radiographs of the joint shall meet the standard for radiography given in the ASME Power Boiler Code, par. P-102 (h) (8) to allow the operator to weld.

Examination by sectioning may be made in lieu of radiographic examination. The welded joint shall be quartered and one side of each of the four cuts shall be etched. Each etched section shall conform to the requirements of par. UW 52 (e) (4) of the 1952 ASME Unfired Pressure Vessel Code.

If objectionable defects are disclosed by the above methods of examination, it shall be cause for examination by the same method of the second and subsequent joints welded by the operator under the machine welding procedure, until the operator demonstrates that he is capable of carrying out the provisions of the procedure.

Each manufacturer or contractor shall maintain a record of the procedures under which welding operators are examined and the results of the examination.

Subp. 3. Performance qualification of welders. Each welder who welds on piping constructed under the rules of this code shall pass the tests prescribed herein for performance qualification. Operators of machine welding equipment as

MINNESOTA RULES 1991

5165

PIPEFITTERS; POWER PIPING SYSTEMS 5230.1100

defined in subpart 2 are excluded. The essential variables of the qualification and the test results obtained by each welder shall be recorded as a performance qualification. A recommended form for recording the performance qualification test results is given in part 5230.1110, subparts 1 and 2.

Subp. 4. Essential variables. A welder must be requalified whenever one or more of the changes listed below are made in the procedure specification. Changes other than those listed do not require requalification. A welder that prepares welding procedure qualification test welds meeting the requirements of part 5230.1090, subpart 4 is thereby qualified.

A. W-1 A change from the filler metal used in a performance qualification to a filler metal having a different F-number. Qualification under any F-number up to and including F4 shall qualify a welder for all lower F-numbers. For example, a welder who qualified with number F4 electrodes is thereby qualified to weld with electrodes listed under numbers F1, F2, and F3. Independent qualifications are required for numbers F5 and F6.

B. W-2 The addition of other welding positions than those already qualified. See part 5230.1080, subparts 4 and 5.

C. W-3 A change from upward to downward or from downward to upward in the progression specified for any pass of a vertical weld, other than a wash pass.

D. W-4 The omission of the backing ring in arc-welding single-welded butt joints.

E. W-5 The addition of the backing ring in gas welding.

F. W-6 A change from one welding process to any other welding process.

Subp. 5. Preparation of test joint. Test joints shall be prepared as follows:

A. The base material, the filler material, and the welding shall comply with the essential variables entered in the procedure specification, except as otherwise specified in item E.

B. The base material shall consist of pipe having a minimum nominal diameter of five inches and a minimum wall thickness of one-fourth inch.

C. The dimensions of the welding groove for the test joint used in making performance qualification tests on single-welded butt joints with backing ring shall be the same as those for any procedure specification qualified by the manufacturer, or contractor.

D. The dimensions of the welding groove for the test joint used in making performance qualification tests on single-welded butt joints without backing ring shall be the same as those for any procedure specification qualified by the manufacturer.

E. Where a welder is to be qualified with electrodes conforming to ASTM A 316 or A 298, and the proper size pipe materials are not readily available, carbon steel pipe may be substituted for the performance test with the following limitations:

(1) Performance qualification with low-alloy steel electrodes (F-numbers 1, 2, 3, and 4) using carbon steel pipe material is permissible, provided the test specimens are preheated, welded, and postheated in accordance with the procedure specification for the type electrode involved, and further provided that the total alloy content of the weld metal deposit does not exceed six percent.

(2) Performance qualification with austenitic electrodes (F-number 5) using carbon steel pipe material is permissible. No preheating or postheating is required.

Subp. 6. Type and number of test specimens. The types and number of specimens required for a performance qualification are given in part 5230.1270, subpart 1, figure 10, together with the range of thickness that is qualified for use in construction by a given wall thickness of test pipe used in making the qualifica-

tion. All specimens shall be tested and shall meet the requirements prescribed in part 5230.1080, subpart 8.

Two specimens shall be removed from test welds as shown in part 5230.1270, subparts 1 and 2, figures 10 and 11 at approximately 90 degrees apart, with the pipe in the horizontal rolled and vertical fixed position. See part 5230.1260, figure 9. Four specimens shall be removed from the 45 degrees positions of the test weld made with the pipe in the horizontal fixed position. See parts 5230.1260 and 5230.1270. All four specimens shall be tested in order to qualify the welder. Face-bend tests shall be made when required on the specimens from the first and third quadrants part 5230.1270, subpart 1, figure 10. Root-bend tests shall be made, when required, on the specimens from the second and fourth quadrants part 5230.1270, subpart 1, figure 10.

Subp. 7. Retests. A welder who fails to meet the requirements for one or more of the test specimens may be retested. The welder shall make a new test weld for each position on which he has failed, all of which shall pass the test requirements.

Subp. 8. Requalification. Requalification under a given procedure specification shall be made when there is a specific reason to question his ability to make welds that meet the specification. Requalification need be made in only a single test pipe thickness.

Statutory Authority: *MS s 326.46*

5230.1110 RECOMMENDED FORMS OF PROCEDURE SPECIFICATION.

Subpart. 1. Metal arc-welding process.

Procedure Specification for metal arc-welding of _____

Specification No _____ Date _____

Process. The welding shall be done by the metal arc process.

Base metal. The base material shall conform to the specifications for _____ (insert here references to standard ASME, ASTM, API, or other code designations, or give the chemical analysis and physical properties).

Filler metal. The filler metal shall conform to Classification Number _____ of the ASTM Specification for _____ (insert here the title of the desired specification).

Position. The welding shall be done in the _____ (give the position or positions in which the welding will be done. See part 5230.1080, subpart 5).

Preparation of base material. The edges or surfaces of the parts to be joined by welding shall be prepared by _____ (state whether sheared, machined, ground, gas cut, etc.), as shown on the attached sketches and shall be cleaned of all oil or grease and excessive amounts of scale or rust. (The sketches referred to should show the arrangement of parts to be welded with the spacing and details of the welding groove, if used. Such sketches should be comprehensive and cover the full range of material or base metal thicknesses to be welded.)

Electrical characteristics. The current used shall be _____ (state whether direct or alternating and if alternating give the frequency). The base material shall be on the _____ (state whether negative or positive when direct current is used) side of the line.

Joint welding procedure. The welding technique, such as electrode sizes, and mean voltages and currents for each electrode, shall be substantially as shown on the attached sketches. (The sketches referred to may be the same as mentioned under "preparation of base material" or may be separate sketches. They should show, for the minimum thickness and for several intermediate thicknesses of base material, the welding technique to be used, whether weaving or beading, the number of layers or passes and diameter of electrode with the mean voltage and current for each layer or pass, and in the case of vertical welds the progression of each pass, whether upward or downward.)

MINNESOTA RULES 1991

5167

PIPEFITTERS; POWER PIPING SYSTEMS 5230.1110

NOTE: Since, in the welding of many materials in the flat position and particularly for the ordinary mild steels, the proper welding "heat" can be readily determined by the appearance of the individual beads of welding, the use of a "standard appearance weld" may be desirable for the flat position. Such a weld should be made in the maximum thickness that will be used in construction, except that the maximum thickness of the standard appearance weld need not exceed three-fourths inch and should show approximately two inches of the surface of each layer, and a cross section through the weld at each layer, where such cross section is found necessary to produce a clearly understandable photograph. When a standard appearance weld is used, the following paragraph should be used in lieu of specifying current and voltage values.

Appearance of welding layers. The welding current and manner of depositing the weld metal shall be such that the layers of welding as deposited shall have the appearance shown on the photographs attached hereto. There shall be practically no undercutting on the side walls of the welding groove or the adjoining base material.

Cleaning. All slag or flux remaining on any bead of welding shall be removed before laying down the next successive bead.

Defects. Any cracks or blow holes that appear on the surface of any bead of welding shall be removed by chipping, grinding, or gouging before depositing the next successive bead of welding.

Peening. (If peening is to be used, it shall be incorporated as part of the specifications, a description being given of the degree of peening to be done.)

Treatment of under side of welding groove. (The method of preparing the under or second side of a groove for welding on that side should be stated in this paragraph.)

Preheating and temperature control. (This paragraph should describe any preheating and control of temperature during and after welding that will be done.)

Heat treatment. (This paragraph should describe any heat treatment or stress relieving that is given the welded parts before or after welding.)

Subp. 2. Oxyacetylene welding process.

Procedure specification for Oxyacetylene welding of _____

Specification No _____ Date _____

Process. The welding shall be done by the oxyacetylene process.

Base metal. The base material shall conform to the specifications for _____ (insert here references to standard ASME, ASTM, API or other code designations, or give the chemical analysis and physical properties.

Filler metal. The filler metal shall conform to Classification Number _____ of the ASTM Specification for _____ (insert here the title of the desired specification).

Position. The welding shall be done in the _____ (give the position or positions in which the welding will be done. See part 5230.1080, subpart 5).

Preparation of base material. The edges or surfaces of the parts to be joined by welding shall be prepared by (state whether sheared, machined, ground, gas-cut, etc.) as shown on the attached sketches and shall be cleaned of all oil or grease and excessive amounts of scale or rust. (The sketches referred to should show the arrangement of parts to be welded with the spacing and details of the welding groove, if used. Such sketches should be comprehensive and cover the full range of material or base metal thicknesses to be welded.)

Size of welding tip. The range in size of welding tips used shall be as shown on the attached sketch. (The sketches referred to may be the same as mentioned under "preparation of base material" or may be a separate set. They should show the range of tip sizes for each thickness of material).

5230.1110 PIPEFITTERS; POWER PIPING SYSTEMS

5168

Nature of flame. The flame used for welding shall be _____ (state whether a neutral flame or one with slight excess of acetylene is to be used).

Method of welding. The method of welding shall be that known as _____ (describe whether "backhand" or "forehand").

Size of welding rod. The size of rod used for the various base material thicknesses shall be as shown on the attached sketch. (The sketches referred to may be the same as mentioned under "preparation of base material," or may be a separate set.)

Number of layers of welding. The number of layers of welding used shall be as shown on the attached sketches. (The sketches referred to may be the same as mentioned under "preparation of base material" or may be a separate set. They should show the range of thicknesses for which one, two, or more layers are used.)

Cleaning. All slag or flux remaining on any layer of welding shall be removed before laying down the next successive layer.

Defects. Any cracks or blow holes that appear on the surface of any layer of welding shall be removed by chipping, grinding, or gas gouging before depositing the next successive bead of welding.

Peening. (If peening is to be used it shall be incorporated as part of the specifications, a description being given of the degree of peening to be done.)

Treatment of under side of welding groove. (The method of preparing the under or second side of a groove for welding on that side should be stated in this paragraph.)

Preheating and temperature control. (This paragraph should describe any preheating and control of temperature during and after welding that will be done.)

Heat treatment. (This paragraph should describe any heat treatment or stress relieving that is given the welded parts before or after welding.)

Statutory Authority: *MS s 326.46*

5230.1120 MATERIALS; THEIR SPECIFICATIONS AND IDENTIFICATION.

Subpart 1. **Scope.** This code includes requirements for marking component parts of piping systems which are made in accord with the standards and specifications named in the appendix to this section, and the policy of the sectional committee in making reference to standards and specifications.

Subp. 2. **Marking.** All valves, fittings, flanges, bolting, pipe, and tubing shall be marked in accordance with the marking sections of the standards and specifications to which reference is made in the code, or in accordance with the requirements of MSS SP-25, Standard Marking System for Valves, Fittings, Flanges and Unions of the Manufacturers Standardization Society of the Valve and Fittings Industry.

Subp. 3. **Materials.** All materials used in piping systems designed and constructed under the provisions of this code shall be capable of meeting the physical and chemical properties and tests as set forth in the appropriate specifications given in the individual sections of the code and listed in the appendix to this section. It is strongly recommended that the materials covered by these specifications be used. However, other materials, the specifications for which are not listed but which have properties equal or superior to the minimum requirements herein given, may also be used in accordance with section requirements.

Subp. 4. **Standards and specifications; policy.** Unless otherwise specified, the reference "American Standard" in this code shall mean the latest revision of the standard for the particular purpose as approved by the American Standards Association. The use of the latest revisions of all other standards or specifications mentioned in this code is intended.

The lack of year designation of the numerous dimensional standards and material specifications to which reference is made, and which are, in effect, made a part of the code in so far as they apply, is recognized. It is, however, not considered practicable to refer to a specific edition of each of these standards and specifications in individual sections because they are likely to be revised much more frequently than is this large basic code, and frequent revision of this code just to keep the designation of the reference standard or specification up to date is not considered desirable. Instead, the American National Standard Code for Pressure Piping, Power Piping, published by ASME in New York, the 1983 edition as amended includes specific edition references and will be revised at short intervals as needed.

Statutory Authority: *MS s 326.46*

5230.1130 FITTINGS FOR INSTRUMENT AND CONTROL PIPING.

Subpart 1. Scope. This appendix covers the descriptions of and specification references to the various types of fittings permissible for use with instrument and control piping, covered under part 5230.1020.

Subp. 2. High-pressure. High-pressure service:

A. Flared fittings requiring a flaring tool:

(1) The construction of the tube end of flared fittings (i.e., tubing end of connector body, nut, and sleeve when used) shall conform to Specification Mil-F-5509 for minimum performance requirements, except that all straight threads shall be class 2. Modifications may be used if test performance conforms with the requirements of subitem (3).

(2) The angle of flare of tubing shall be 37 degrees from the centerline, or 74 degrees included angle, and flare dimensions shall be in accord with Army-Navy Design 10061.

(3) The test performance shall equal or exceed the requirements of Specification Mil-F-5506.

(4) All pipe threads shall be either American Standard Taper Pipe Threads, ASA B2 or Dryseal American Standard Taper Pipe Threads, NPTF.

B. Flareless fittings. Flareless fittings of which the male connector shall be of a style whereby the gripping member shall grip or bite into the outer surface of the tube, thereby holding the tube against pressure, without appreciably distorting the inside tube diameter. The gripping member also forms a pressure seal against the body of the fitting.

When the bite-type fitting is used, the joint shall first be made up tight, then disassembled to make sure the depth of "bite" is adequate, and then reassembled.

When the grip-type fitting is used, the outside diameter of the tubing must be determined by "no-go" gage applied to the tube at right angles to each other at the point where the fitting will grip it, to be within the tolerance established by the fitting manufacturer.

The test performance shall equal or exceed the requirements of specification Mil-F-5506.

C. Socket-welded fittings. Socket-welded fittings shall conform in general design to ASA B16.11.

D. Silver-brazed socket-type fittings. Silver-brazed socket-type joints for valves and fittings shall be made with suitable brazing alloys having melting points above 1000 degrees Fahrenheit. Socket depth shall be the equivalent of thread length in fittings of the same diameter and pressure class, and a shoulder shall be provided for the pipe or tubing to butt against. Silver-brazing alloy shall either be end-fed into the fittings, or shall be provided in the form of a preinserted ring in a groove in the fitting. The brazing alloy shall be sufficient to completely fill the annular clearance between the socket and the pipe or tubing.

MINNESOTA RULES 1991

5230.1130 PIPEFITTERS; POWER PIPING SYSTEMS

5170

Subp. 3. **Medium-pressure.** Medium-pressure service:

A. flared type in accordance with SAE General Specifications, Figs. 1 to 4, and Tables 1 and 2, 1949 SAE Handbook;

B. inverted flared type in accordance with SAE General Specifications, Fig. 18, and Tables 11 and 12, 1949 SAE Handbook;

C. compression type, in accordance with SAE General Specifications, Figs. 9 through 13 and Tables 5 and 6 for service up to 500 psi 100 degrees Fahrenheit up to one-half inch tube, 250 psi for larger tubes.

Subp. 4. **Low-pressure.** Low-pressure service:

A. soldered type, per American Standard for Soldered Joint Fittings, ASA B16.18, for service under the following limitations;

B. maximum pressure 50 psi, with max. line temperature well below melting point of solder so as to minimize failure due to creep under load.

Statutory Authority: *MS s 326.46*

MINNESOTA RULES 1991

5171

PIPEFITTERS; POWER PIPING SYSTEMS 5230.1210

5230.1200 FIGURE 3: RECOMMENDED END PREPARATIONS.

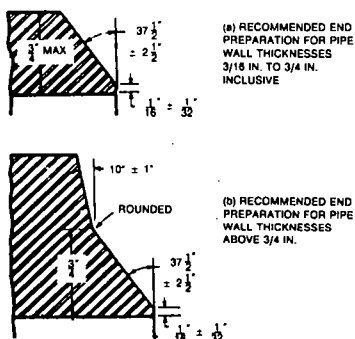

Statutory Authority: *MS s 326.46*

5230.1210 FIGURE 4: BUTT WELDING OF PIPES OR FITTINGS OF UNEQUAL WALL THICKNESSES.

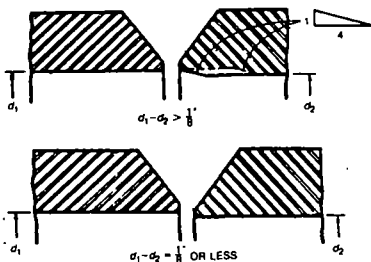

Statutory Authority: *MS s 326.46*

5230.1220 PIPEFITTERS; POWER PIPING SYSTEMS

5172

5230.1220 FIGURE 5: TYPICAL JOINTS WITH BACKING RING.

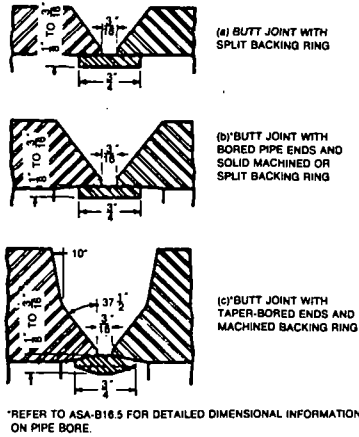

Statutory Authority: *MS s 326.46*

5230.1230 FIGURE 6: DETAILS OF WELDING FLANGES.

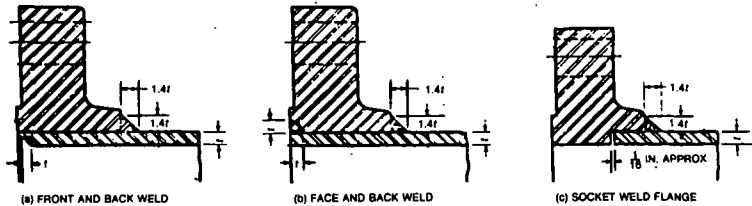

Statutory Authority: *MS s 326.46*

5230.1240 FIGURE 7: MINIMUM DIMENSIONS REQUIRED FOR SOCKET WELD FITTINGS.

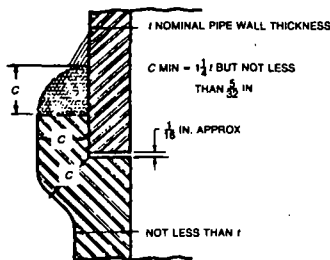

Statutory Authority: *MS s 326.46*

MINNESOTA RULES 1991

5173

PIPEFITTERS; POWER PIPING SYSTEMS 5230.1250

5230.1250 FIGURE 8: POSITIONS OF GROOVE WELDS.

BUTT WELDS IN PIPE IN WHICH THE AXIS OF THE PIPE AT THE JOINT DOES NOT DEVIATE FROM THE HORIZONTAL BY MORE THAN $\pm 30^\circ$ AND THE PIPE IS ROTATED SO THAT THE WELDING IS ALWAYS DONE WITHIN $\pm 15^\circ$ OF A VERTICAL PLANE AT THE JOINT.

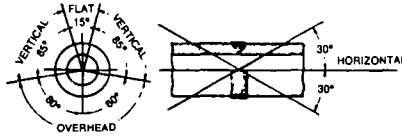

(Horizontal Rolled Position-Flat Weld)

BUTT WELDS IN PIPE IN WHICH THE AXIS OF THE PIPE AT THE JOINT DOES NOT DEVIATE FROM THE VERTICAL BY MORE THAN $\pm 10^\circ$ AND THE PIPE MAY OR MAY NOT BE ROTATED DURING WELDING SO THAT A HORIZONTAL WELD IS PRODUCED AROUND THE ENTIRE CIRCUMFERENCE.

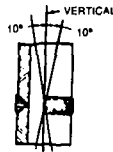

WHEN THE PIPE IS FIXED AND THE AXIS OF THE PIPE AT THE JOINT DEVIATED FROM A HORIZONTAL PLANE BY MORE THAN $\pm 30^\circ$ AND FROM THE VERTICAL BY MORE THAN $\pm 10^\circ$, THE WELDING WILL BE DONE IN A COMBINATION OF HORIZONTAL AND OVERHEAD POSITIONS.

(Vertical Fixed Position-Horizontal Weld)

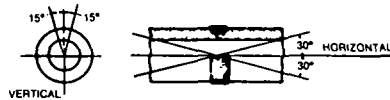









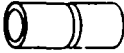

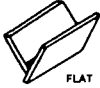







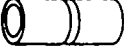

BUTT WELDS IN PIPE IN WHICH THE AXIS OF THE PIPE AT THE JOINT DOES NOT DEVIATE FROM THE HORIZONTAL BY MORE THAN $\pm 30^\circ$ AND THE PIPE IS FIXED IN THIS POSITION SO THAT THE WELDING IS DONE IN A COMBINATION OF FLAT VERTICAL AND OVERHEAD POSITIONS OF WELDING. (As Shown in the Sketch Above).

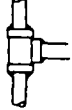
(Horizontal Fixed Position-Flat, Vertical, and Overhead Welds)

Statutory Authority: *MS s 326.46*

5230.1260 FIGURE 9: QUALIFYING POSITIONS.

BASIC QUALIFICATION TEST:	GROOVE WELDS IN PLATE	ALSO QUALIFIES FOR:	
		PIPE	FILLET WELDS IN
			PIPE
 <p>PIPE-HORIZONTAL ROLLED WELD FLAT</p>	 <p>FLAT</p>	 <p>ROLLED</p>	 <p>FLAT</p>
 <p>PIPE-VERTICAL FIXED WELD-HORIZONTAL</p>	 <p>FLAT</p>  <p>HORIZONTAL</p>	 <p>HORIZONTAL</p>  <p>ROLLED</p>	 <p>FLAT</p>  <p>HORIZONTAL</p>
 <p>PIPE-HORIZONTAL FIXED WELD-FLAT, VERTICAL AND OVERHEAD</p>	 <p>FLAT</p>  <p>VERTICAL</p>  <p>OVERHEAD</p>	 <p>HORIZONTAL, VERTICAL AND OVERHEAD</p>  <p>ROLLED</p>	 <p>VERTICAL</p>  <p>FLAT</p>  <p>HORIZONTAL</p>  <p>OVERHEAD</p>

Qualifying Positions in Groove Welds in Pipe and Corresponding Allowable Working Positions in Groove Welds in Plate and Fillet Welds in Pipe and Plate

Statutory Authority: *MS s 326.46*

MINNESOTA RULES 1991

5175

PIPEFITTERS; POWER PIPING SYSTEMS 5230.1270

5230.1270 ORDER OF REMOVAL OF TEST SPECIMENS.

Subpart 1. Figure 10.

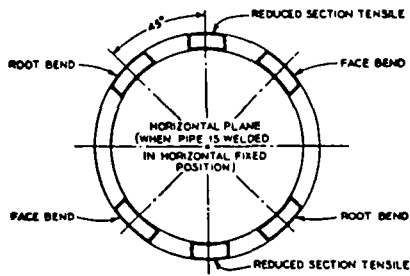

Order of Removal of Test Specimens from Welded Pipe (For Pipe 1/16 to 3/4 in. Thick).

Subp. 2. Figure 11.

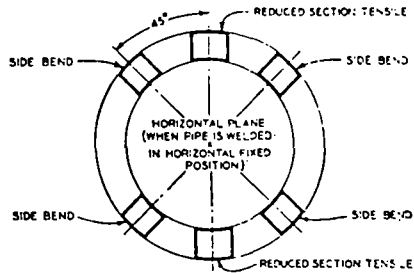

Order of Removal of Test Specimens from Welded Pipe (For Pipe over 3/4 in. Thick)*
*May be used also for Thicknesses 3/8 in. to 3/4 in.

Statutory Authority: *MS s 326.46*