

**CHAPTER 1365  
DEPARTMENT OF ADMINISTRATION  
STATE BUILDING CODE  
APPENDIX ON SNOW LOADS**

1365.0200 VARIATIONS OF SNOW LOADS.  
1365.0300 CALCULATING INCREASES OR DECREASES.  
1365.0400 TABLE OF PITCH VERSUS DEGREE.  
1365.0500 VALLEY AREA OF SLOPED ROOFS.

1365.0600 LOWER LEVEL OF MULTILEVEL ROOFS.  
1365.0700 LOWER ROOF WITH SLOPING UPPER ROOF.  
1365.0800 PROJECTIONS AND OBSTRUCTIONS.

**1365.0200 VARIATIONS OF SNOW LOADS.**

The minimum snow loads for the design of both ordinary and multiple series roofs, either flat, pitched, or curved, shall be determined by multiplying the appropriate snow load given in UBC section 2305(c) by the appropriate coefficients  $C_s$  (see parts 1365.0500 to 1365.0800). The full intensity of the roof snow load shall be applied to any one contiguous portion of the roof area if it produces a more unfavorable effect than the full intensity applied over the entire roof area.

**Statutory Authority:** *MS s 16B.59 to 16B.73*

**1365.0300 CALCULATING INCREASES OR DECREASES.**

Subpart 1. **Decreases.** The basic snow load coefficient  $C_s$  shall be increased or decreased in accordance with the following conditions:

A. A decrease (due to slide-off of snow load) on the horizontal projection of pitched roofs, of one pound per square foot for each degree, by which the slope angle exceeds 20 degrees. In no case shall the allowable design load be less than 20 pounds per square foot.

B. A decrease of 20 percent of the basic uniform snow load may be used for rounded (arch) roofs with a ratio of rise to span between 1/8 and 3/8. Roofs with rise to span ratio equal to or greater than 3/8, the basic uniform snow load may be reduced 40 percent. In no case shall the allowable uniform snow load be less than 20 pounds per square foot.

Subp. 2. **Increases.** The basic roof loads shall be increased for the following conditions:

A. Roof valley condition in accordance with part 1365.0500 and applicable load cases.

B. Roof areas abutting vertical walls, of adjacent buildings in accordance with part 1365.0600 and applicable formulas.

C. Lower level roof areas abutting sloping upper roof areas in accordance with part 1365.0700 and applicable descriptive conditions.

D. Roof areas adjacent to or containing projections and/or obstructions in accordance with part 1365.0800 and applicable formulas.

**Statutory Authority:** *MS s 16B.59 to 16B.73*

**1365.0400 TABLE OF PITCH VERSUS DEGREE.**

Pitch	Degrees
2/12	9° -28'
2-1/2/12	11° -46'
3/12	14° -2'
3-1/2/12	16° -15 1/2'

# MINNESOTA RULES 1985

493

## APPENDIX ON SNOW LOADS 1365.0400

4/12	18°-26'
4-1/2/12	20°-33'
5/12	22°-37'
5-1/2/12	24°-37'
6/12	26°-34'

**Statutory Authority:** *MS s 16B.59 to 16B.73*

# MINNESOTA RULES 1985

## 1365.0500 VALLEY AREA OF SLOPED ROOFS.

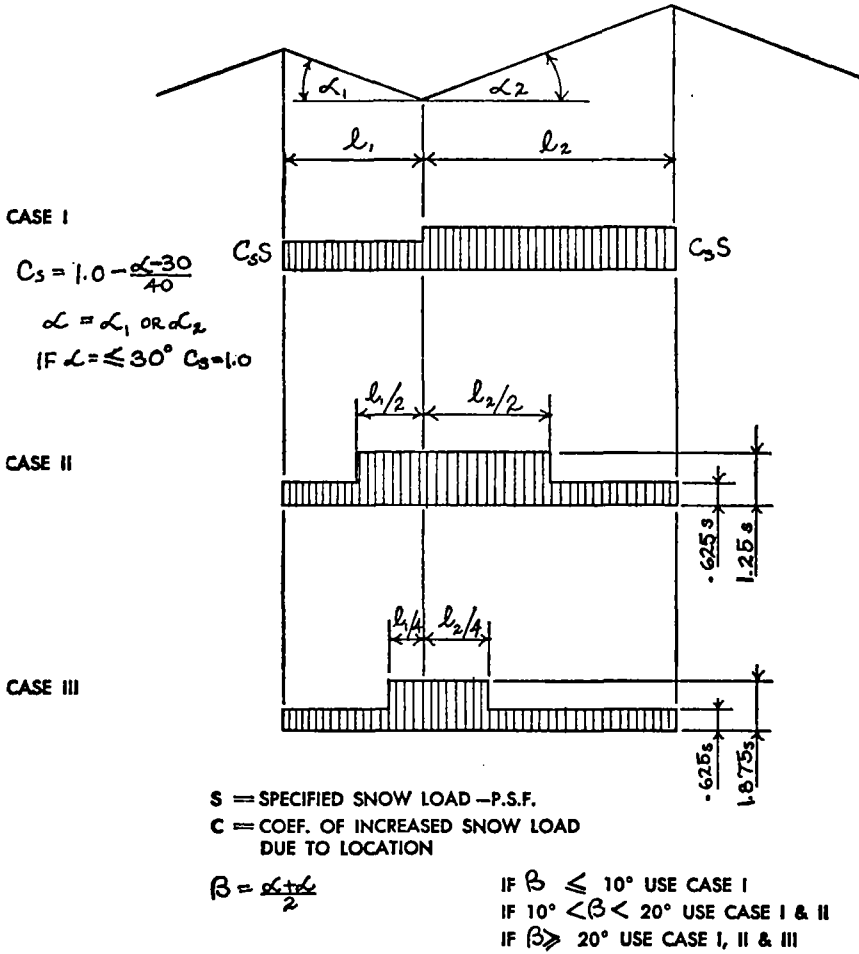

Statutory Authority: MS s 16B.59 to 16B.73

# MINNESOTA RULES 1985

495

APPENDIX ON SNOW LOADS 1365.0600

## 1365.0600 LOWER LEVEL OF MULTILEVEL ROOFS.

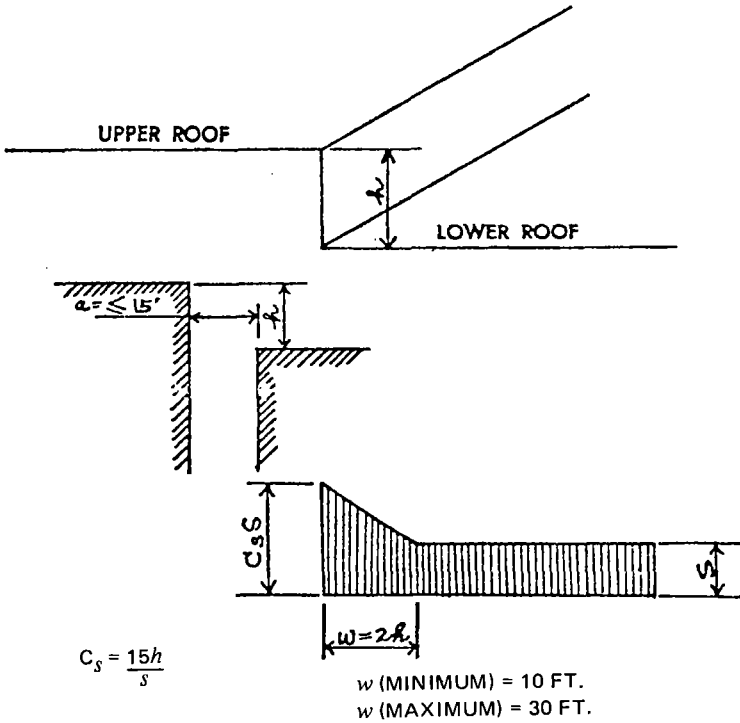

IF $\frac{15h}{s} < 1.0$	$C_s = 1.0$	IF $h < 5 \text{ FT.}, w = 10 \text{ FT.}$
IF $\frac{15h}{s} > 3.0$	$C_s = 3.0$	IF $h > 15 \text{ FT.}, w = 30 \text{ FT.}$

- $h$  = HEIGHT DIFFERENCE IN ROOFS IN FEET
- $w$  = WIDTH OF DRIFT IN FEET
- $a$  = DISTANCE BETWEEN BUILDINGS IN FEET
- $s$  = SPECIFIED SNOW LOAD IN P.S.F.
- $C_s$  = COEFFICIENT OF INCREASED SHOW LOAD

Statutory Authority: *MS s 16B.59 to 16B.73*

# MINNESOTA RULES 1985

## 1365.0700 APPENDIX ON SNOW LOADS

496

### 1365.0700 LOWER ROOF WITH SLOPING UPPER ROOF.

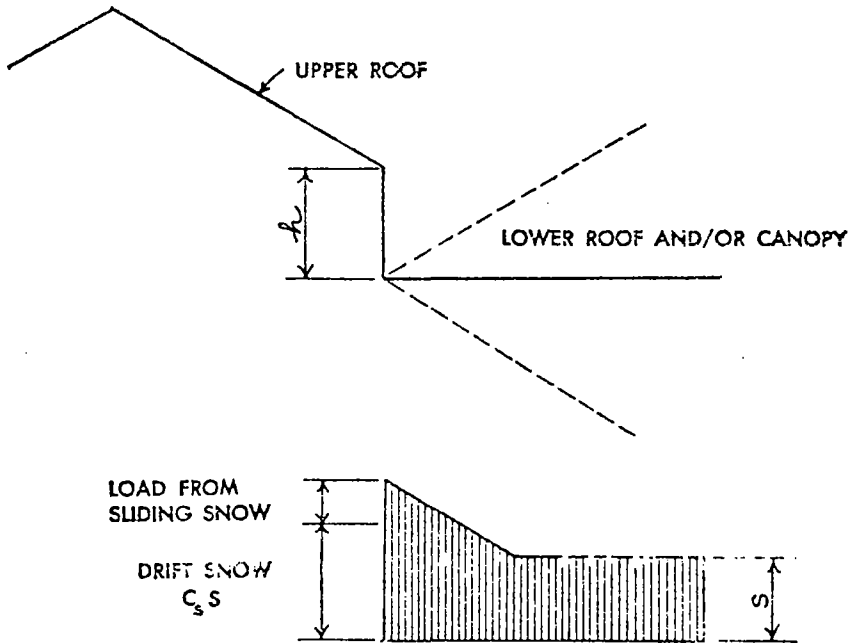

DESIGN LOWER ROOF OR CANOPY FOR LOADS ACCORDING TO FIGURE II + 50% of DESIGN LOAD FROM UPPER. THE DISTRIBUTION SHOULD BE MADE DEPENDING ON THE RELATIVE SIZES, SLOPES AND POSITIONS OF THE TWO ROOFS.

IF, BECAUSE OF A RELATIVELY SMALL LOWER ROOF OR CANOPY, ALL OF THE SLIDING SNOW CANNOT BE RETAINED, APPROPRIATE REDUCTIONS MAY BE MADE. THE DENSITY OF SLIDING SNOW MAY BE RATHER HIGH.

DESIGN UPPER ROOF AS THOUGH IT IS A SINGLE SPAN BUILDING.

Statutory Authority: *MS s 16B.59 to 16B.73*

# MINNESOTA RULES 1985

497

APPENDIX ON SNOW LOADS 1365.0800

## 1365.0800 PROJECTIONS AND OBSTRUCTIONS.

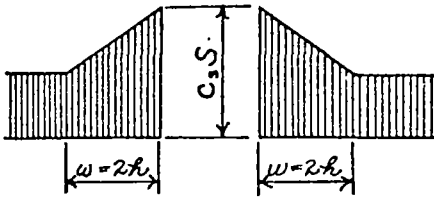
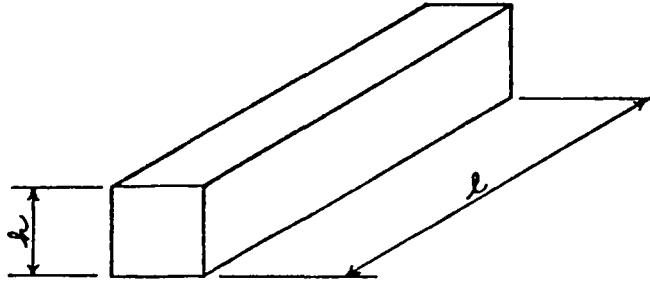

w (MINIMUM) = 10 FEET  
w (MAXIMUM) = 30 FEET

$$C_s = \frac{10h}{s}$$

IF  $\frac{10h}{s} < 1.0$   $C_s = 1.0$

IF  $h < 5$  FEET  $w = 10$  FEET  
IF  $h > 15$  FEET  $w = 30$  FEET

IF  $\frac{10h}{s} > 2.5$   $C_s = 2.5$

IF  $l < \frac{s}{4.8}$   $C_s = 1.0$

- $h$  = HEIGHT OF OBSTRUCTION IN FEET
- $w$  = WIDTH OF DRIFT IN FEET
- $l$  = LENGTH OF OBSTRUCTION OR PROJECTION IN FEET
- $s$  = SPECIFIED SNOW LOAD IN P.S.F.
- $c$  = COEFFICIENT OF INCREASED SNOW LOAD

Statutory Authority: MS s 16B.59 to 16B.73